

# L100 Peristaltic Pump

www.enviroflexpumps.com | +44 (0) 1332 913 200 | sales@enviroflexpumps.com



## PUMP SPECIFICATIONS

**PUMP (HOSE) BORE**  
100mm (4")

**MAX WORKING PRESSURE**  
10 BarG (145 PSI)

**DISPLACEMENT PER REV**  
26 L/REV (6.868 US GAL/REV)

**MAX CONTINUOUS SPEED**  
30 RPM

**MAX INTERMITTENT SPEED**  
35 RPM

**SOLIDS HANDLING**  
Soft: 80mm (3") Hard: 15mm (19/32")

**MAX SUCTION LIFT (WATER)**  
9 Meters (27 Feet)

**AVERAGE STANDARD WEIGHT**  
900 KG (1980 LB)

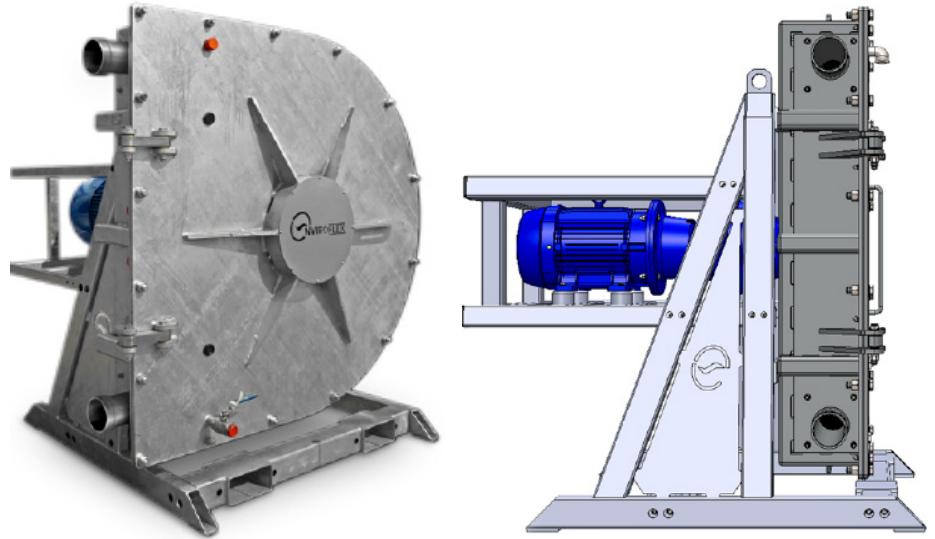

## RUBBER HOSE MATERIALS

- Natural (NR)
- Food Grade Natural (FGNR)
- Nitrile Buna (NBR)
- Food Grade Nitrile Buna (FGNBR)
- Ethylene Propylene Diene Monomer (EDPM)
- Chlorosulfonated Polyethylene (CSM)
- Fluorine/Fluoro (FKM)

## CONNECTION OPTIONS

- Victaulic (standard)
- ANSI Class 150 Flanged
- PN16 Flanged
- Tri-Clamp\*
- IDF
- RJT
- Camlock

## GA DRAWING

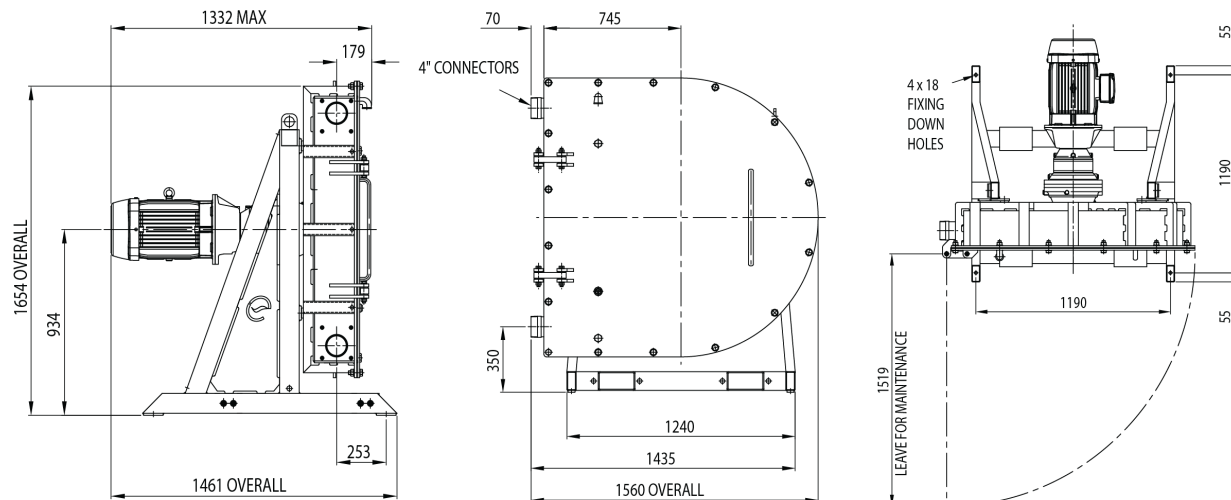

## L100 PERFORMANCE CURVE

