

L150 Peristaltic Pump

www.enviroflexpumps.com | +44 (0) 1332 913 200 | sales@enviroflexpumps.com



PUMP SPECIFICATIONS

PUMP (HOSE) BORE
150mm (6")

MAX WORKING PRESSURE
10 BarG (145 PSI)

DISPLACEMENT PER REV
70 L/REV (18.492 US GAL/REV)

MAX CONTINUOUS SPEED
25 RPM

MAX INTERMITTENT SPEED
35 RPM

SOLIDS HANDLING
Soft: 120mm (4-3/4") Hard: 22.5mm (7/8")

MAX SUCTION LIFT (WATER)
9 Meters (27 Feet)

AVERAGE STANDARD WEIGHT
1800 KG (3960 LB)

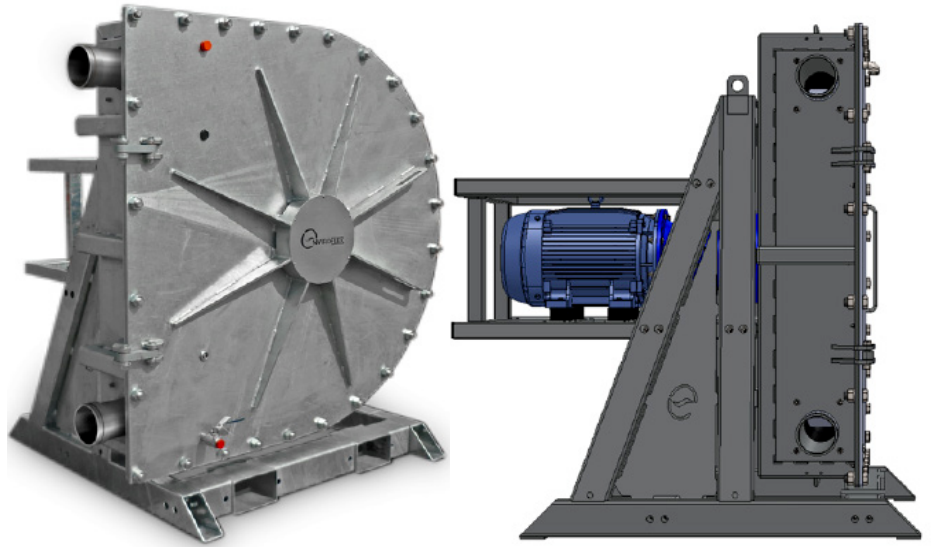

RUBBER HOSE MATERIALS

- Natural (NR)
- Food Grade Natural (FGNR)
- Nitrile Buna (NBR)
- Food Grade Nitrile Buna (FGNBR)
- Ethylene Propylene Diene Monomer (EDPM)
- Chlorosulfonated Polyethylene (CSM)
- Fluorine/Fluoro (FKM)

CONNECTION OPTIONS

- Victaulic (standard)
- Tri-Clamp*
- ANSI Class 150
- Flanged
- PN16 Flanged
- IDF
- RJT
- Camlock

GA DRAWING

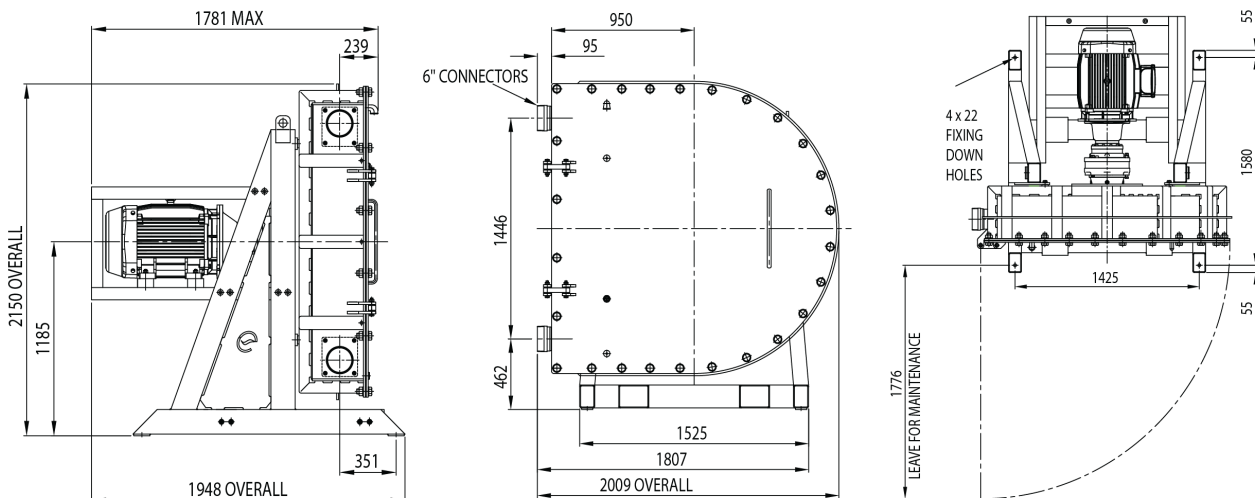

L150 PERFORMANCE CURVE

