

ENVIROFLEX® L SERIES

L20 to L80 Peristaltic Pumps

Installation, Operation & Maintenance Manual

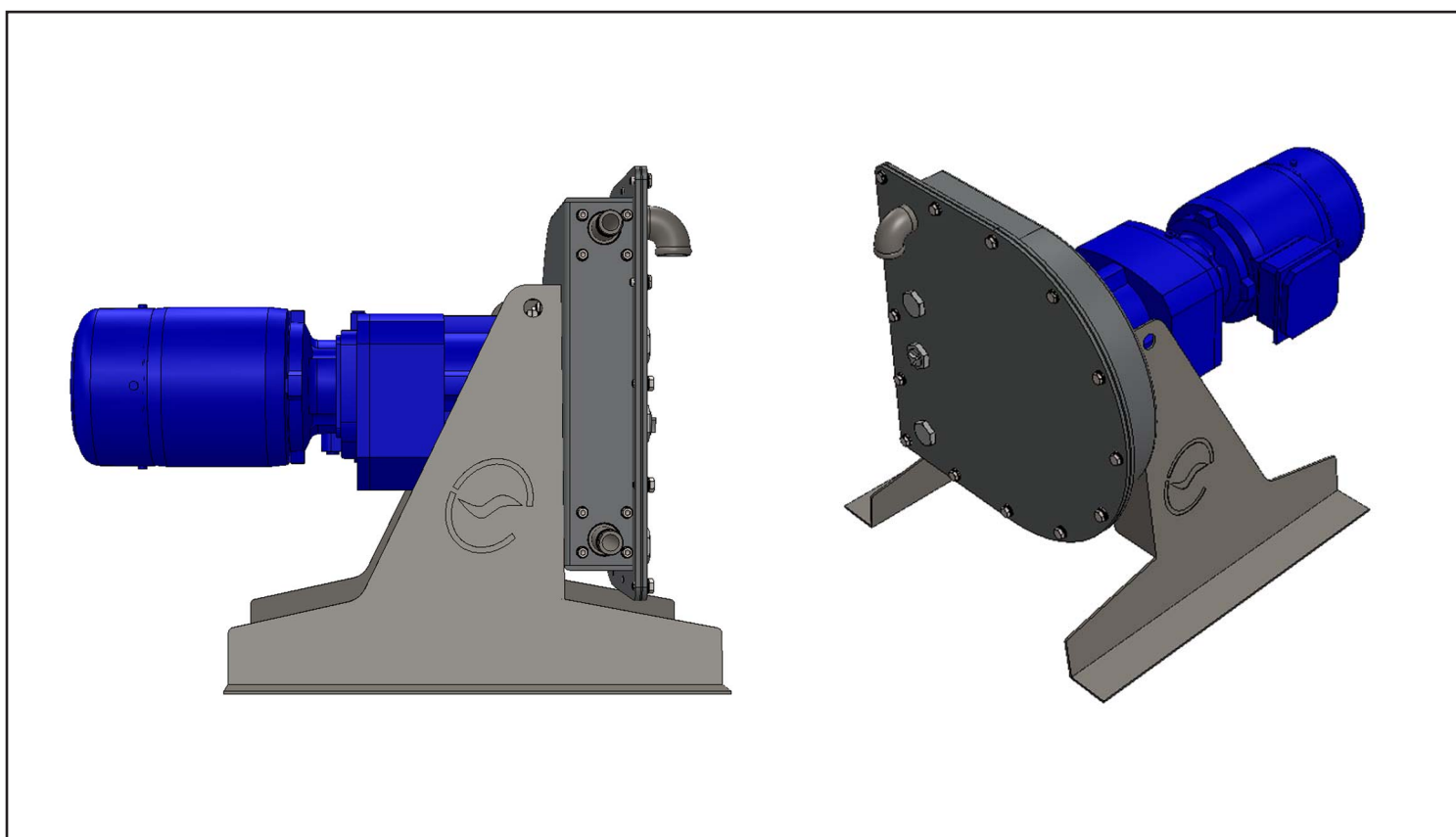

BEFORE INSTALLING YOUR PUMP HAVE YOU.....

- Read this Manual in its entirety?
- Ordered recommended spares? (spares not always in stock)
- Checked we have shown the correct pump duty on the data sheet?
- Checked pump supplied as per the technical data sheet?
- Installed overpressure protection for the pump?
- Protected the pump motor against over current?
- Installed suitable pulsation dampeners where required?
- Completed all Pre start-up checks highlighted in this manual?

Tick

Manual Revision 1 December 2012



Clickable Contents:

1	Introduction	4
1.1	General	4
1.2	Safety	5
1.3	Intended Use	5
1.4	Warranty Conditions	6
1.5	Description	6
1.5.1	Operation of the pump	6
1.5.2	Pump hose	7
1.5.3	Hose Lubrication	7
1.5.4	Drive systems	8
1.5.5	Available options	8
2	Installation	9
2.1	Unpacking	9
2.2	Storage	9
2.3	Locating the Pump	9
2.4	Connecting the Pipe work	10
2.5	Pulsations	11
2.6	Lifting the Pump	12
2.7	Mounting the Pump	12
2.8	Electrical Connection	12
2.9	Use of Frequency Inverters	13
2.10	ATEX Approved Units	13
2.11	Commissioning	14
2.11.1	Prestart-up Checks	14
2.11.2	Start-up Checks	14
3	Maintenance	15
3.1	Routine Maintenance	15
3.2	Cleaning the pump Hose	16
3.3	Hose Removal	16
3.4	Replacing the Roller Bushes	17
3.5	Adjusting the Compression Rollers	18
3.6	Fitting the Pump Hose	18
3.7	Fitting the Front Cover	21

3.8	Rotor Removal	21
3.9	Gearbox Drive Removal	21
3.10	Gearbox Drive Replacement	22
3.11	Rotor Replacement	23
3.12	Hose Connector Assembly	23
3.13	Sectional Drawing & Parts List	24
4	User Guide	38
4.1	Troubleshooting	38
4.2	Specifications	40
4.2.1	Pump operating conditions	40
4.2.2	Materials of Construction	40
4.2.3	Hose Lubricant Quantities	41
4.2.4	Weights and Dimensions	41
4.3	Recommendations for Hose Storage	42
4.4	EC Declaration of Conformity	43
4.5	Product Use Declaration Form	44

Contact Information:

Manufacturer

Environmental Pumping Solutions Limited
 Elcot Park
 Elcot Lane
 Marlborough
 Wiltshire
 SN8 2BG
www.environmentalpumping.co.uk

Authorised Distributor

Tel: 0800 0180 007 Fax: 01672 515 650

International Tel: +44 (0) 1672 519 878
 International Fax: +44 (0) 1672 515 650

Manual Revision 1 December 2012

The information contained in this document is believed to be correct but neither Environmental Pumping Solutions nor its distributors or representatives accept any liability for any errors or omissions and reserves the right to alter any specifications without notice.

This manual is owned by Environmental Pumping Solutions Limited and may not be reproduced by any means in part without their written consent. Reproduction by the user for the purposes of Installation, Operation and Maintenance of their L Series peristaltic pump only excepted.
 Copyright 2009 - 2012 All rights reserved.

1 Introduction

Thank you for choosing a quality pump from Environmental Pumping Solutions Ltd.

Critical information before start up:



For safety reasons and in order for you to get the full usage of your new pump, it is necessary to read this manual thoroughly before putting it into service.

Ensure all commissioning checks on page 14 have been carried out

Within 7 days of delivery and before mounting and installing the pump please make sure that the unit corresponds exactly to that ordered and has not been damaged during transport.

This manual is divided into 4 parts:

1. **Introduction** to give the user an overview of the pump and this manual.
2. **Installation Guide** for installing or uninstalling and commissioning the pump.
3. **Maintenance Guide** for maintenance, repair or troubleshooting.
4. **User Guide** for daily use of the pump.

The L series pump range provides a high quality product that is designed to provide reliability, low energy consumption and low maintenance costs.

Environmental Pumping Solutions Ltd supplies the complete range of peristaltic hose pumps including 10mm (3/8"), 15mm (1/2"), 20mm (3/4"), 25mm (1"), 32mm (1 1/4"), 40mm (1 1/2"), 50mm (2"), 65mm (2 1/2"), 80mm (3"), 100mm (4") and 150mm (6").

1.1 **General**

These instructions are intended as a reference book by means of which qualified users are able to install, commission and maintain Environmental Pumping Solutions L series peristaltic pumps. These instructions do not absolve the user of responsibility for carrying out work in accordance with good engineering practices and adherence to local Health & Safety regulations.

Documentation on the drive system used with the pump is not included within this manual. Reference must be made to separate documentation for the drive system, and its recommendations and instructions strictly observed.

For further information specifically about the L series range of peristaltic pumps which is not found within these instructions, please contact Environmental Pumping Solutions Limited, or your authorised local dealer.

Please ensure you have the following data at hand:

- serial number of the pump
- material of the pump hose
- serial number of the drive gearbox and motor

Identification plates are mounted on the pump head, drive gearbox and electric motor.

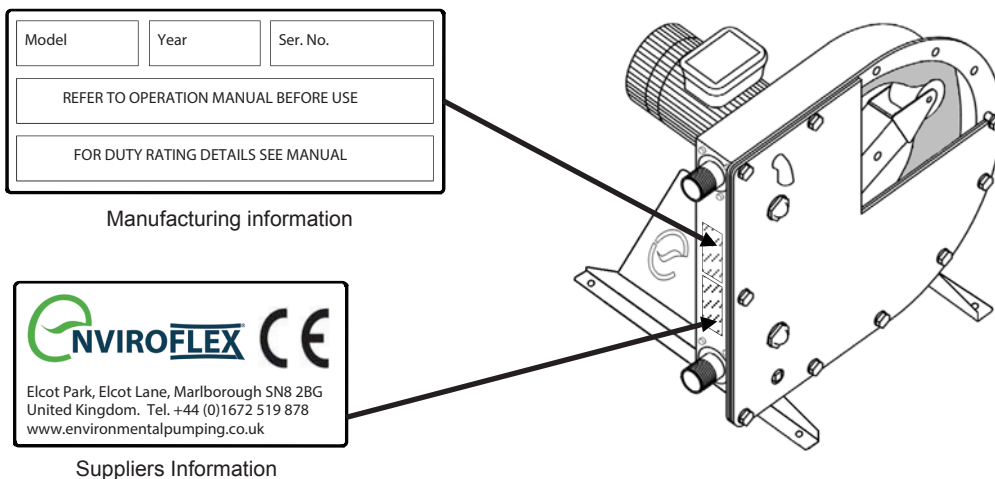

Labels fixed to the pump body contain model type, year of manufacture, product serial number and manufacturer's details.

1.2 Safety

In these instructions the following symbols are used:

	<p>WARNING Procedures, which, if not carried out with the necessary care, may result in serious damage to the pump equipment or in serious bodily harm.</p>
	<p>CAUTION Procedures not carried out with the necessary care, may result in serious damage to the pump equipment, the surrounding area or the environment.</p>
	<p>Remarks, suggestions and advice.</p>

During installation & maintenance all personnel should ensure they wear suitable personal protection equipment (PPE) such as safety glasses, gloves, safety boots and safety helmets as appropriate.

1.3 Intended Use

Environmental Pumping Solutions L series peristaltic pumps are designed exclusively for pumping suitable products as defined in the technical data sheet supplied with your final quotation. Every other or further use is not in conformance with the "intended use" as laid down in EN 292-1.(1) The manufacturer cannot be held responsible for damage or harm resulting from use other than the "intended use".

If you wish to change the application of your pump, please contact Environmental Pumping Solutions Limited, or your authorised local dealer to establish if the change is appropriate for the supplied pump.

(1) The "Intended use" as laid down in EN 292-1 is "... the use for which the technical product is intended in accordance with the specifications of the manufacturer, inclusive of his indications in the sales brochure". In case of doubt it is the use which appears to be its intended use judging from the construction, execution and function of the product. Observing the instructions in the user's documentation also belongs to intended use.

1.4 **Warranty Conditions**

Unless stated otherwise in the Technical Selection Sheet provided at the time of pump selection, the manufacturer offers a two-year warranty on proper workmanship of all parts of the pump. Exclusion is made for normal wear and tear of consumables, such as pump hoses, lubricant, hose clamps, compression rollers, bearings and bushes, wear ring and seals, or parts which have been misused or damaged through negligence.

The warranty only applies if the pump has been used for the application specified in the technical selection sheet and according to the guidance in this manual. Operation at pressures outside of the range specified in the Technical Selection Sheet shall invalidate this warranty.

This manufacturer's warranty is null and void for any user who uses parts not of Environmental Pumping Solutions Limited original supply in their L series peristaltic pump (including use of an alternative hose lubricant).

The warranty is strictly a return to base warranty, which means that the pump is required to be returned to our UK factory by arrangement for any investigation, replacement or repair work. The cost of transport back to our factory is not covered by this warranty; however with any valid warranty claim all time, replacement parts and carriage back to the original delivery address are included.

Any parts to be returned to the manufacturer must be accompanied by a fully filled in and signed declaration form declaring the conditions of use and materials pumped. Parts which have been contaminated or which have been corroded by chemicals or other substances which can pose a health risk must be cleaned before they are returned to the manufacturer.

Furthermore, it should be indicated in the declaration form what specific cleaning procedures have been followed, and that the equipment has been decontaminated.

The declaration form is required for all items, even if the parts have not been used.

A Declaration Form can be found at the end of this manual.

Warranties purporting to be on behalf of Environmental Pumping Solutions Limited made by any person, including representatives of Environmental Pumping Solutions Limited, its subsidiaries, or its distributors, which do not accord with the terms of this warranty shall not be binding upon Environmental Pumping Solutions Limited unless expressly approved in writing by a Director of Environmental Pumping Solutions Limited.

1.5 **Description**

1.5.1 Operation of the pump

The heart of the L series peristaltic pump is a specially constructed pump hose which lies within the pump housing. (Upon pump installation both ends of this hose are connected to the suction and discharge lines). A rotor with two opposing compression rollers lies in the centre of the pumphead.

During pump operation the rotor rotates, with the compression rollers compressing the pump hose. This action "pushes" the pumped fluid through the hose, and as soon as the compression

roller has passed, the hose recovers to its original shape due to the mechanical properties of the material.

Simultaneously fresh pumped fluid is drawn into the hose behind the compression roller by the (continuous) turning motion of the rotor.

The second compression roller will subsequently compress the pump hose. Due to the continuous rotating movement of the rotor not only is new product sucked in, but the already present product is pushed out by the moving compression roller. When the first compression roller leaves the pump hose, the second compression roller has already closed the pump hose and the product is prevented from flowing back. This is known as the “positive displacement principle” pumping principle.

1.5.2 Pump hose

The pump hose is made of specially compounded rubbers, reinforced with nylon cords. The outer cover of the pump hose is always made of natural rubber, whilst the inner layer is supplied in a variety of materials to suit the product to be pumped.

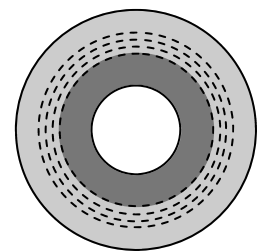

Dependent on the specific requirements of your application a corresponding pump hose must be selected. For each pump model various hose types are available.

i Consult Environmental Pumping Solutions Limited or your authorised local dealer for more detailed information about the range of hoses available, and their chemical and temperature resistance.

Environmental Pumping Solutions pump hoses have been carefully machined, to ensure minimum tolerances in wall thickness. It is very important to guarantee the correct compression of the pump hose, because over compression can cause too high a load on the pump and pump hose leading to reduced pump hose life and gearbox failure.

Under compression will result in loss of capacity and backflow resulting in reduced pump hose life.

i Please refer to the maintenance section of this manual regarding adjustment of hose compression settings.

1.5.3 Hose Lubrication

The pumphead is part filled with our specially compounded Envirolube lubricant. The lubricant lubricates the compression rollers and movement between the hose and the pump housing and the cover.

To those familiar with other types of peristaltic pumps utilising compressions shoes, our lubricant may appear thin, but this is essential in order to reach the roller bearings with maximum efficiency of lubrication.

Our lubricant is the result of decades of development and is perfectly mixed for use specifically in the L series pumps, ensuring the hose is fully lubricated at all times with no reaction on the hose material that would cause swelling and early hose failure.

Environmental Pumping Solutions Envirolube lubricant will not freeze during cold weather.

1.5.4 Drive systems

The L series pumps described in this manual use a variety of drive types. Motors and gearboxes are selected according to the particular application for which the pump is applied.

1.5.5 Available options

The following options are available for the L series range of pumps:

- Hose Failure Detectors (senses elevated lubricant levels within the pump as a result of hose failure)
- Flanged pipework connections
- Complete stainless steel pumps

2 Installation

2.1 *Unpacking*

Upon unpacking of the pump check and inspect all items against the purchase order and packing list and for any damage caused during shipment. All claims for shortages and/or damage must be notified immediately to Environmental Pumping Solutions Limited.



Suitable lifting equipment must be used when handling components and assembling pumps.



ENVIRONMENT

When disposing of unwanted packaging materials, please consider the possibilities for reuse or environmentally friendly processing of packaging materials. Always observe local regulations with respect to disposal of non reusable items.

2.2 *Storage*

After receipt and inspection, if pumps are not to be put into service immediately provision should be made for the pump to be rotated for a couple of turns on a weekly basis, ensuring the rollers are not allowed to come to rest in the same position consecutively. Alternatively one roller can be removed from the pump, leaving the remaining roller not in contact with the hose between the inlet and outlet ports.



Failure to adhere to the above procedure may result in a 'permanent set' of the hose which can result in reduced performance and premature hose failure.

Pumps that are to be stored for extended periods of time should have the hoses removed and stored in accordance with Environmental Pumping Solutions recommendations. The pumps should be repackaged and placed in a suitable clean dry storage area free from excess moisture and vibrations. Protective blanking caps fitted before despatch from the factory should not be removed. Any unpainted surfaces not factory treated with a rust inhibiting coating should have a protective coating applied.

Where applicable, if pumps were supplied with electric motors fitted with anticondensation heaters, these should be connected to a temporary supply and switched on throughout the storage period.

2.3 *Locating the Pump*



Before mounting the pump, make sure that all your site safety procedures have been reviewed and that any appropriate risk assessments have been completed.



Upon installation ensure that all markings on the pump will be clearly visible when installation is complete.

Ensure the pump is to be sited in an area where the ambient temperature during operation is not below -15° and above $+45^{\circ}\text{C}$.

Check that the foundation where the pump is to be mounted can carry the load of the pump. Also have the appropriate SWL marked lifting gear / crane ready for the given situation.

Ensure the foundation/floor surface is flat and horizontal. Minor irregularities in surface level can be accommodated by the use of shims placed under the support frame.

Ensure there is sufficient room around the pump to carry out the necessary maintenance activities. Particularly ensure the front cover door can be opened and a hose taken out and replaced (If it cannot, it maybe possible to modify the door to remove the hinge if fitted, please enquire).

Ensure the installation environment is sufficiently ventilated allowing heat developed by the pump and drive to be discharged, particularly that the motor cowl has sufficient air to circulate to support cooling.

No special tools are required to install the L series pumps, other than ordinary hand tools and a hammer/drilling machine for the installation of the foundation bolts.

2.4 **Connecting the Pipework**

It is recommended that the connection to a pipe system is made as a flexible joint. There are several flexible systems on the market which include both metallic and rubber systems.

By making a flexible joint, the risk of introducing vibrations into the complete pipe system is reduced. Vibrations may cause wear and in some cases fatigue fractures in the pipe system.

The pipework system must be independently supported and must not use the pump in anyway to support its weight (The pipe system must never hang by the connections of the pump).

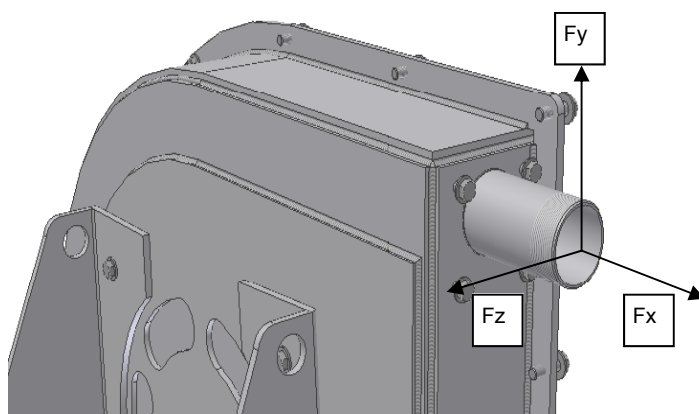

Permissible Load (N)			
	L20 & 25	L32	L40
Fx	600	600	800
Fy	150	150	200
Fz	150	150	200
	L50	L65	L80
Fx	1000	1200	1500
Fy	200	300	300
Fz	200	300	300

Suction line bore must be larger than the bore size of the pump hose. Discharge line bore must be the same or larger than the bore size of the pump hose.

Keep the suction and delivery lines as short and direct as possible.

Suction and discharge lines should preferably exit straight from the pump so that the pump is not pumping directly into a restriction for example a 90 degree bend, as this may cause the hose to come off. Where bends are used, ensure the radiuses are as large as possible. It is recommended to use Y-connections instead of T-connections.

Prevent any possibilities of exceeding the maximum working pressure of the pump. It is essential that you discuss this with your system designers in order to ensure safe system and pump operation. If necessary fit an overpressure protection device.



To avoid misunderstanding, protecting the motor against over current will not protect the pump from overpressure. Pump overpressure needs to be protected against independently using a pipeline mounted overpressure protection device.

All L series pumps have a pressure overflow connection found on the front of the pump above the lubricant fill plug. When the pump hose fails, liquid will come out of this overflow connector. If this is a potential safety or hygienic issue, the connector will need to be piped back to a safe location in a way that will not impede normal atmospheric pressure reaching the pump body during normal operation.



Consider the maximum permissible working pressure of the pump and pipework used. Exceeding maximum working pressures may lead to serious damage.

2.5 ***Pulsations***

Some systems require pulsation dampers to avoid excessive and damaging pressure spikes and vibrations. Situations that may lead to excessive pulsations and vibration are:

- incorrectly secured pipelines
- high pump speeds with long suction and delivery lines or the product SG is high
- pipeline bore is too small

Where unacceptable pulsations are encountered, it may be possible to install pulsation dampeners to alleviate the problems.

Dampeners need to be sized very carefully in order to protect the pump and system from excessive pressure peaks.

- Never use an existing dampener employed on another application or pump make and assume it will automatically work on an application with an L series pump. Different pump displacements and system characteristics often mean a dampener will not work effectively.
- Many dampeners are not suitable for variable speed applications. Where pump speeds and pressures vary, dampeners need to be carefully selected and sized to accommodate all the duty conditions.



Consult Environmental Pumping Solutions Limited or your authorised local dealer for more detailed information about the need and use of pulsation dampeners.

2.6 *Lifting the Pump*

The complete pump should be lifted using the lifting eyes on the pump frame. Due to the selection of drives available the centre of lift will vary dependant upon the size and weight of the drive fitted. If desirable to lift the pump squarely an additional lifting strap may be positioned around the juncture of the gearbox and motor. The length of this will need to be adjusted to establish a level lift if so desired. Suitably rated lifting straps or slings only must be used. Gearbox and motor lifting eyes must not be used for lifting the complete pump unit.

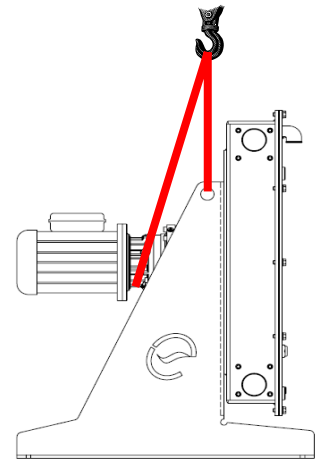

When lifting the pump ensure that all standard lifting practices are adhered to and carried out by qualified personnel only.

2.7 *Mounting the Pump*

The pump is fastened to the foundation via the holes in the frame or pump-chassis using suitable anchor bolts.

If the pump is to be mounted on rubber pads, it is very important that the connecting pipeline is fitted with a flexible joint.

2.8 *Electrical Connection*



Electrical connection of the pump must only be done by suitably qualified personnel.

The motor is to be thermally protected against overload by a protective circuit switch and is to have the correctly sized fuse according to the local existing rules and regulations.

Important:

In order to insure that the pump remains free of static electricity, the pump needs to be grounded. This is done via the grounding of the motor. The motor must be grounded with a wire of sufficient size!

For electrical connection details, please see the motor datasheet.

The pump should have its own dedicated electrical isolation switch meeting the requirements of BS EN 60947 - 3 (Switches, disconnectors, switch disconnectors and fuse combination units) so that it is not possible to start the pump during maintenance. There should also be an emergency stop button meeting the requirements of BS EN 60947 - 5 - 1 (Electro - mechanical control circuit devices) and BS EN 60947 - 5 - 5 (Electrical emergency stop devices with mechanical latching function.)

It is recommended to have local electrical control to the pump for use during commissioning and maintenance operations.

These electrical items should be installed according to the manufacturer's instructions by an electrician qualified to install electrical equipment on machinery.

If the pump is incorporated into a more complex installation then the installer should ensure the completed installation complies with the Machinery Directive 2006/42/EC.

2.9 ***Use of Frequency Inverters***

The pump will not come with a motor that is suitable for use with a frequency inverter unless this has been stated on the pump technical data sheet.

Use of an inverter when no allowance has been made for one, can be dangerous and may lead to motor failure.

Where the use of an inverter has been specified on the pump technical data sheet it is essential that the control panel does not allow an operator to run the pump outside of the turndown design parameters there specified.

Frequency inverters used with peristaltic hose pumps must be of the constant torque type, and ideally sized at least one size larger than the pump fitted motor kilowatts.

2.10 ***ATEX Approved Units***



Standard L series pumps must not be used in potentially explosive hazardous atmospheres (European Directive 94/9/EC -ATEX Directive). If you require a pump to operate in a hazardous area classification, please contact Environmental Pumping Solutions Limited or your authorised local dealer for more detailed information.

2.11 Commissioning

2.11.1 Prestart-up Checks

Before commissioning, carry out the following checks:

- Check the pipework connections, ensuring there is no undue strain on the pipework.
- Ensure that there are no obstructions such as closed valves in the pipework. It is advisable to flush the system through with water to clear any debris.
- Ensure the Transport Plug is removed from the pressure overflow connection on the front of the pump.
- Check the pump casing is filled to the correct level with Envirolube specially compounded Roller Hose Lubricant. If necessary add lubricant. - **Before adding lubricant, check you have the correct hose lubricant; fill only with our Roller grade lubricant.**
- Check there is oil in the gearbox, and filled to the correct level.

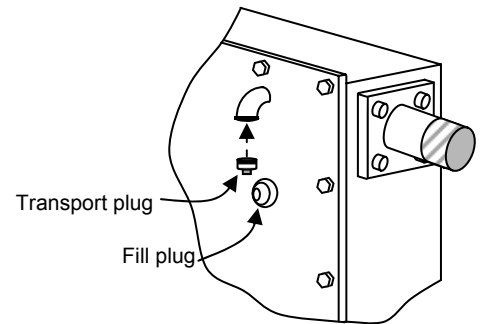

It is advisable prior to powering up the pump to check rotation by hand to ensure there are no obstructions. This can be achieved as follows:

Isolate and lock off the electrical supply. Remove the motor fan cowl and turn the electric motor fan by hand to ensure free running. The motor should be rotated for enough turns to ensure the pump rotor has turned through 360 degrees. (If the gearbox ratio is 50:1, the motor fan must be rotated 50 revolutions). If any difficulties are found these should be investigated and rectified.

2.11.2 Start-up Checks

Prepare the electric motor for operation in accordance with the manufacturer's instructions, and ensure pump control panels are energised ready for operation.

When satisfied that all preliminary checks and procedures have been carried out, start up the pump.

Whilst running carry out the following checks:

- Check the rotation of the rotor.
- Check for any leaks in the system
- Check for excessive vibrations
- Check the pumping capacity of the pump.

Generally monitor the behaviour of the pumpset during the run period, ensuring that temperatures stabilise within the run period.

Check the integrity of the foundation holding bolts.

Following all start-up checks, if any items deviate from expected, refer to the "Troubleshooting" section of this manual or contact Environmental Pumping Solutions Limited, or your authorised local dealer.

3 Maintenance



Only use original Environmental Pumping Solutions parts when maintaining the pump. Environmental Pumping Solutions Limited cannot otherwise guarantee correct functioning of the pump. Any consequential damage that occurs from the use of non-original components cannot be warranted.

3.1 Routine Maintenance

The L series pumps are designed to minimise service and maintenance.

A small number of simple preventive measures are however needed in order to ensure continuous and trouble free pump life.

Important: it is very important, that the pump is maintained according to the table below.



Never clean or repair the pump without it being fully isolated.

When cleaning, maintaining or repairing the pump, the power supply to the motor has to be disconnected by means of a key locked switch.

Action	To be carried out	Comments
Check hose lubricant level	Before start-up and thereafter on a daily operational basis	Lubricant should be visible in the lower sight glass on the pump front cover
Check the pumphead for any lubricant leakage around the cover and the connections	Before start-up and thereafter on a daily operational basis	
Check pump for high temperature or unusual noise	On a daily operational basis	
Check compression rollers for wear	When replacing the pump hose	Replace if there is more than 1mm wear across the roller
Changing the hose lubricant	When replacing the pump hose	Only use Envirolube hose lubricants
Check gearbox oil level	Before start-up and thereafter on a daily operational basis	
Replacing the gearbox oil	Refer to the gearbox manufacturers instructions	

In certain installations it may be desirable to try and change the pump hose before failure on a routine scheduled basis. If this is the case, we suggest changing the hose after 75% of the time the first hose lasted.

Due to the variety of motor and gearboxes supplied according to both application and client requirements, maintenance detail is not shown in this manual. Please refer to the manufacturer's manual for maintenance detail on your specific drive.

3.2 *Cleaning the pump Hose*

The inside of the pump hose is easily cleaned by flushing with water or any other compatible cleaning fluid. Ensure that the pump hose can not only resist the chemical compatibility of any cleaning fluids, but also the temperature of cleaning liquid used.

Cleaning systems must not generate pressures in excess of the pump operating design pressure.

3.3 *Hose Removal*



When pumping potentially hot, hazardous or dangerous media, it is critical to ensure that personnel are adequately protected during hose removal and that the hose is washed through with a media harmless to man and the environment before the hose is dismantled.



There can be a significant pressure difference between the upper and the lower pump connections. This can mean that while having vacuum in one connecting pipe there can be a large overpressure in the other connecting pipe. It is therefore essential that the pipework is depressurised safely prior to opening the pump cover and dismantling the hose.

Before dismantling any items, shut off the suction and discharge valves.

Drain the hose lubricant by positioning a container at the base of the pump, remove the top fill plug, remove the drain plug at the bottom of the pump and drain the lubricant into the container.



Always dispose of used lubricant in safe and proper manner. Refer to local Environmental restrictions as appropriate.

Unbolt the pump front cover and swing open on its hinges.

There are two options of hose removal with the L series pumps. Either the complete hose and inserts can be removed as one element assembly, or the hose can be removed with the inserts left in the pump.

With both methods of hose removal we suggest that one of the compression rollers is removed. To remove a roller ensure the roller is not in contact with the hose, remove the roller spindle screw and screws holding the roller side plate and lift the roller out. Rotate the rotor so that the remaining roller lies between the inlet and outlet ports. The hose can then be removed and a new one inserted easily without having to rotate the rotor. To refit the compression roller, rotate the rotor 180° so that the roller to be replaced lies between the inlet and outlet ports.

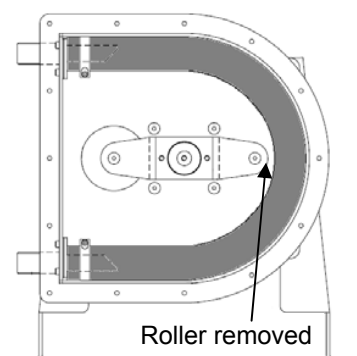

Removing the hose as an Element Assembly

First disconnect suction and discharge piping

Remove the insert retaining bolts from both hose inserts, lift the hose element assembly out of the pump, withdrawing the inserts through the pump body.

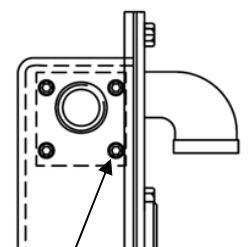

Insert retaining bolts

Removing the hose only

Note: There is no need to disconnect the suction and discharge piping when removing the hose only via this method.

i Where difficulty pulling the hose off the connectors is encountered, try cutting the hose along the side of the connector as shown.

Carefully loosen top and bottom hose clamps.

From the bottom hose connector pull the hose off and out as far as possible. Continue pulling out the old hose until you have arrived at the top hose connection and finally pull the hose off this connection.

Check mechanical parts, such as Rollers, bushings and shafts for damage or wear.

Clean all components thoroughly, flushing with clean water if necessary. Pay particular attention to any residue of pumped material. Deposits of any abrasive media left within the pump body will be detrimental to future component life.

Check before replacing the hose that it is the correct diameter, and material and measure the exact thickness of the hose and note this down. This is needed if adjustment of the rollers is needed.

Before fitting the new hose, we recommend you check the compression roller occlusion setting to ensure optimum pumping efficiency throughout the pump life.

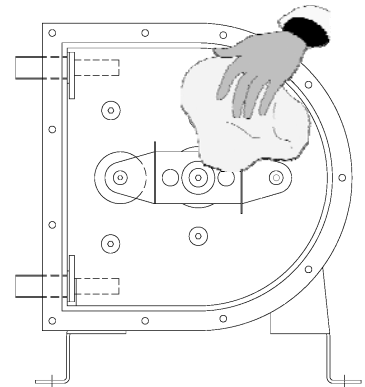
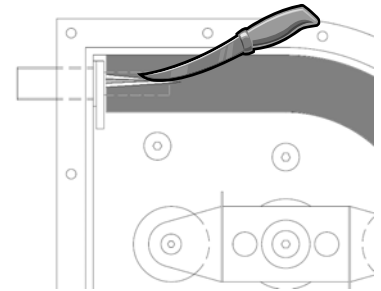

i When ordering spare parts, please make reference to the serial number on the nameplate.

3.4 ***Replacing the Roller Bushes***

With the hose removed, remove the compression rollers if not already done so, by removing the roller spindle screw and lifting the roller out of the roller carrier.

Using a suitable mandrel, press the old bushes out of the roller.

Lightly lubricate the outer surfaces of the new bushes and press into place, ensuring the face of each bush is flush with the face of the roller each side.

Refitting the roller is a reversal of the removal process.

3.5 Adjusting the Compression Rollers

The distance 'A' between the inner face of the pump body housing, and the compression roller should be set according to the following formula:

$$A = (2 \times t) - t1$$

(at pressures 0 to 5 bar)

When the application pressure is to exceed 5 bar, subtract $0,1 \times t1 \times Pd$

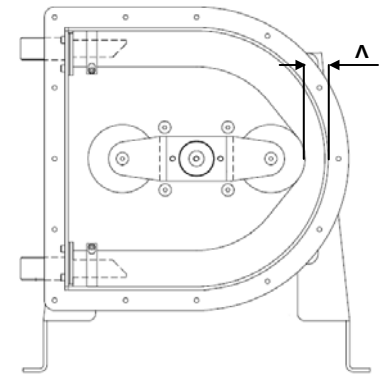

Figure 1 Distance from roller to pump housing

Variable	Value
A	Distance from roller to pump housing, see Figure 1
t	Thickness of the hose wall, see Figure 2
t1	Material dependent scale, see below
Pd	Nominal working pressure on the pump.

Example:

Hose thickness $t = 14 \text{ mm}$

Hose material NBR $t1 = 1.0 \text{ mm}$

Working pressure $Pd = 7 \text{ bar}$

$$A = 2 \times 14 - 1.0 = 27.0 \text{ mm}$$

Subtraction from higher working pressure:

$$0.1 \times 1.0 \times 7 = 0.7 \text{ mm}$$

$$A = 27.0 \text{ mm} - 0.7 = 26.3 \text{ mm}$$

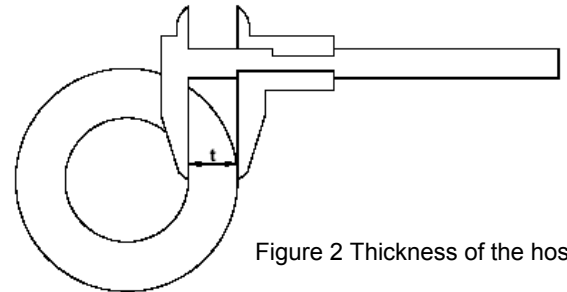

Figure 2 Thickness of the hose

Hose material	Scale: t1	Hose material	Scale: t1
Natural rubber	1,5 mm	Butyl	1,0 mm
NBR (Nitrile)	1,0 mm	Hypalon (CSM)	1,0 mm
EPDM	1,0 mm	Neoprene	1,0 mm

To adjust the compression roller gap shims should be inserted under the roller carrier. Additional shims of 0.5mm and 1.0mm thickness are available from Environmental Pumping Solutions Limited or your authorised local dealer.



The above procedure is intended as a guide only. After carrying out operational tests as detailed later in these instructions it may be found necessary to further adjust the rollers to decrease the distance 'A'.



Should it be found necessary to further adjust the rollers to decrease the distance 'A', this should be done in increments of 0,5 mm. If the rollers are adjusted too much, over occlusion of the hose will occur. Hose over occlusion is detrimental to hose life.

3.6 Fitting the Pump Hose



Take care when fitting the pump hose, there is a possibility of trapping hands if care is not taken.

Ensure the pump body housing is clean and free from foreign particles.

If not already removed, remove one of the compression rollers. To remove a roller ensure the roller is not in contact with the hose, remove the roller spindle screw and screws holding the roller side plate and lift the roller out. Rotate the rotor 180° so that the remaining roller lies between the inlet and outlet ports. The hose can then be inserted easily without having to rotate the rotor. To refit the compression roller, rotate the rotor 180° so that the roller to be replaced lies between the inlet and outlet ports.

Refitting the hose as an Element Assembly

i Prior to installing a new element hose assembly, ensure that both hose inserts are aligned correctly. The hose inserts can only be fitted to the pump in one orientation, checking the correct orientation and alignment now will avoid delays later.

Correct alignment can be achieved by assembly on a flat surface ensuring both insert flanges sit flat on the surface whilst assembly takes place.



It is important to ensure correct alignment of the hose inserts. Misalignment will result in a twisted hose once the hose is fitted, leading to premature hose failure.

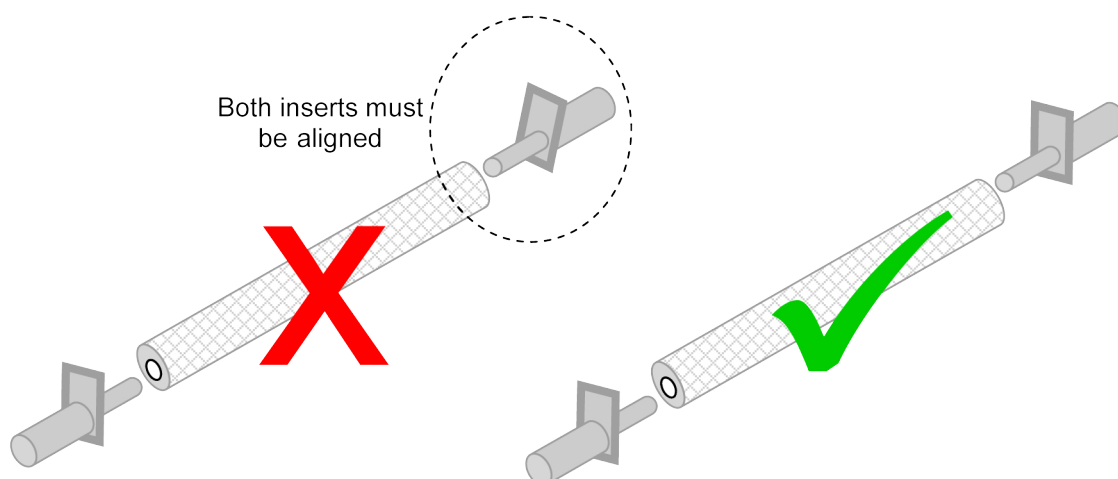

Push the hose onto the hose inserts along with the hose clamps – do not tighten clamps.

i Aid assembly by lubricating inserts and hose bore with hose lubricant.



Never lubricate the hose, or any components in contact with the pump hose with mineral oils or lubricants, these are not compatible with the materials of hose construction.

Ensure the hose is pushed up to the insert flange on both connections, and that the inserts are in correct alignment.

Tighten both hose clamps and re check the insert alignment.

i If the assembled hose element is not to be installed into the pump straight away, ensure the assembly is wrapped and stored in accordance with Environmental Pumping Solutions recommendations.

Prior to fitting to the pump, ensure the hose assembly is clean and free from grit and particles on the outer cover. Place the hose connector gasket over the outer connections.

Insert the hose element assembly in to the pump, passing the outer connections through the respective port in the pump body, with the gaskets on the inside of the pump body.

Insert and tighten the insert retaining bolts.

The hose must now be properly positioned in the pump housing as detailed below.



Failure to correctly position the hose may lead to premature hose failure.

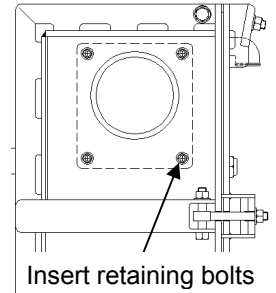

Refitting the hose only (inserts not removed)

Push the hose clamps and hose onto the top connector – do not tighten clamps.



To aid assembly, lubricate the hose connector and hose bore with a little hose lubricant.



Never lubricate the hose, or any components in contact with the pump hose with mineral oils or lubricants, these are not compatible with the materials of hose construction.

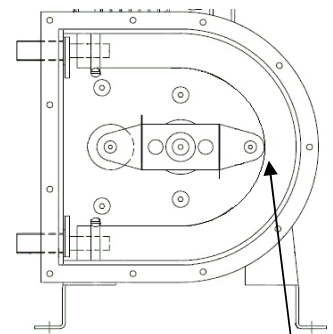

Push the hose over the bottom connector put the hose clamps over the hose - do not tighten clamps.

With the roller removed the hose can be pushed into the housing.

Positioning and Seating the hose

Ensure the hose clamps are loose. (If the hose was fitted as a complete element with inserts, it will be necessary to loosen the clamps.)

Push the hose firmly into the “U” arc of the pump body, ensuring contact is made with the hose and pump body along the complete length of the compression path and then tighten both hose clamps.



If difficulty is found seating the hose against the pump body try refitting the roller as below, the action of the rollers compressing the hose as the pump is rotated will help position the hose.

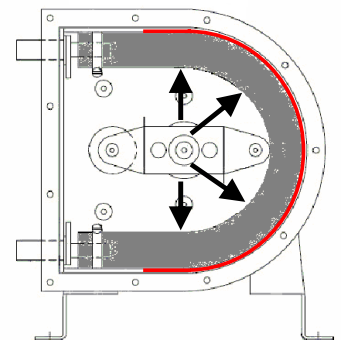

Refit the compression roller, by first rotating the rotor 180° so that the roller to be replaced lies between the inlet and outlet ports.



Always recheck the roller gap after you have refitted the roller.

3.7 **Fitting the Front Cover**

Fit the front cover gasket seal and bolt the front cover to the pump body housing.



Passing a couple of fixing bolts through the front cover and “hanging” the gasket on these will aid with assembly and alignment of the gasket.



Be careful to avoid cross threading. When the cover bolt holes are not fully aligned with the threaded holes in the pump body housing the risk of cross threading the bolts can occur.

Ensure the lubricant drain plug is installed with PTFE tape of similar demountable pipe thread sealant.

Fill the pump housing with the correct quantity of lubricant through the fill plug hole. Once filled you should be able to see the lubricant in the middle of the sight glass at the front of the pump.

Replace the fill plug and check the pump housing for leakage.

If previously disconnected, reconnect all pipework and open all suction and discharge valves.

The pump is now ready for normal operation. Upon restarting check for abnormal vibrations and other irregularities such as abnormal noise.

3.8 **Rotor Removal**

Follow the procedures as detailed earlier for the removal of the pump hose.

Remove the rotor clamp screw & retaining washer and slide the rotor off the shaft.



It is likely that the rotor may be a tight fit on the shaft. Do not hammer the rotor assembly. In such instances use a proprietary puller to extract the complete rotor assembly. Tapped holes are provided in the front of the rotor to insert threaded rod to aid withdrawal from the shaft.

3.9 **Gearbox Drive Removal**

Once the rotor has been removed, the gearbox can be removed if required.

The fixing screws on the L20 through L50 are countersunk headed screws through the rear of the pump housing, with nuts and washers on the gearbox flange. The L65 & L80 pumps utilise fixings through the gearbox flange into threaded holes in the pump body.



Before removing the gearbox fixing bolts ensure the gearbox is adequately supported via the correct lifting method, and that the pump is properly fastened to the floor as removing the gearbox will cause a sudden change in the centre of gravity.

Remove the gearbox fixings and carefully pull the gearbox off the mating spigot, taking care not to damage the drive protection seal in the rear of the pump housing.

Drive Protection Seal Removal

A seal is fitted between the pump and the gearbox. This seal acts as protection for the gearbox drive in the event of a hose failure, reducing the chance of contaminated hose lubricant from reaching the front seal of the gearbox.

i Once the rotor has been removed, the Drive Protection Seal will be seen. Whilst it is possible to remove the seal without gearbox removal, it may be found easier to remove the gearbox in to provide better access to the seal.

A little effort may be needed to remove the gearbox, as the joint may be sealed with a proprietary silicone gasket sealer. Once the gearbox is removed the seal can be removed from the rear of the pump body.

Drive Protection Seal Replacement

Ensure the rear of the pump body is clean where the seal is to be fitted. Lightly lubricate the seal bore with a silicone based lubricant, and using a fly press or similar carefully press the new seal into place, taking care not to damage the seal lip.

3.10 Gearbox Drive Replacement L20 - L50

With the new Drive Protection Seal fitted, the gearbox can be fitted to the pump housing.

Prior to assembly clean and degrease all mating surfaces, ensuring all faces are free from traces of paint and sealants.

Carefully lift the gearbox drive into place taking care not to damage the drive protection seal, and locate the flange spigot on the rear of the pump housing.

Line up the four fixing holes and insert the M8 countersunk socket head screws through the rear of the pump housing.

i Note: the 4 off countersunk screws must have “Instant Gasket” sealant applied under the head before insertion through the pump housing.

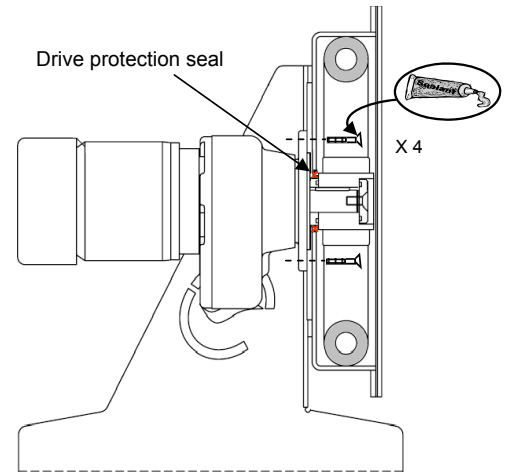

Gearbox Drive Replacement L65 & L80

With the new Drive Protection Seal fitted, the gearbox can be fitted to the pump body housing.

On the L65 pump the gearbox is mounted directly to the pump housing. The L80 utilises a gearbox adapter ring (coloured blue in the drawing) which is mounted directly to the pump housing with the gearbox mounted to this.

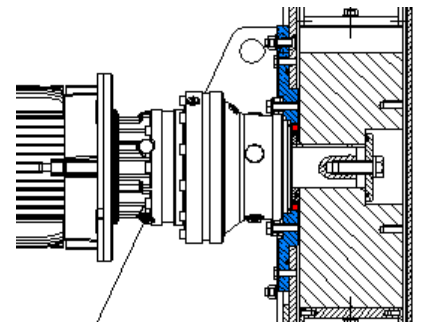

Prior to assembly clean and degrease all mating surfaces, ensuring all faces are free from traces of paint and sealants

On the L80 the gearbox adapter should be mounted to the pump body, ensuring the O-ring seal is fitted into the groove to seal between adapter and pump body housing.

Carefully lift the gearbox drive into place taking care not to damage the drive protection seal whilst ensuring the flange spigot on the gearbox is fully located.

Line up the fixing holes and insert the socket head screws fastening with spring washers.

3.11 **Rotor Replacement**

Clean the bore of the rotor assembly and rotor spacer, applying a small amount of anti-seize compound such as Copaslip® to the bores and keyways.

Slide first the rotor spacer onto the shaft locating it in the bore of the drive protection seal, followed by the rotor assembly. The rotor spacer acts as a wearing surface for the drive protection seal as well as ensuring the rotor is correctly positioned in the pump housing. In the stainless steel pump option there will be an O ring seated in the end of the spacer. Ensure this O ring faces outwards, sealing against the rear of the rotor.



Do not hammer the rotor assembly if the shaft is a tight fit in the rotor, pull the rotor onto the shaft with a long bolt.

Fit the rotor clamp washer and countersunk retaining screw. In the stainless steel pump option there will be an O ring seated in the rear face of the clamp washer. Ensure this O ring faces inwards, sealing against the front of the rotor.

3.12 **Hose Connector Assembly**

The hose connector inserts may be fitted independently, rather than as a hose element assembly. After first ensuring all mating faces are clean, fit the gaskets over the threaded connection of each hose connector.

Insert hose connector in to the pump, passing the threaded connection through the respective port in the pump body, with the gaskets on the inside of the pump body.

Insert and tighten the insert retaining bolts.

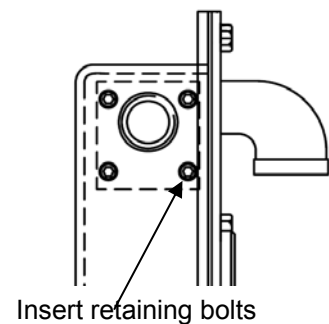



Exploded View for L20 Series Pump

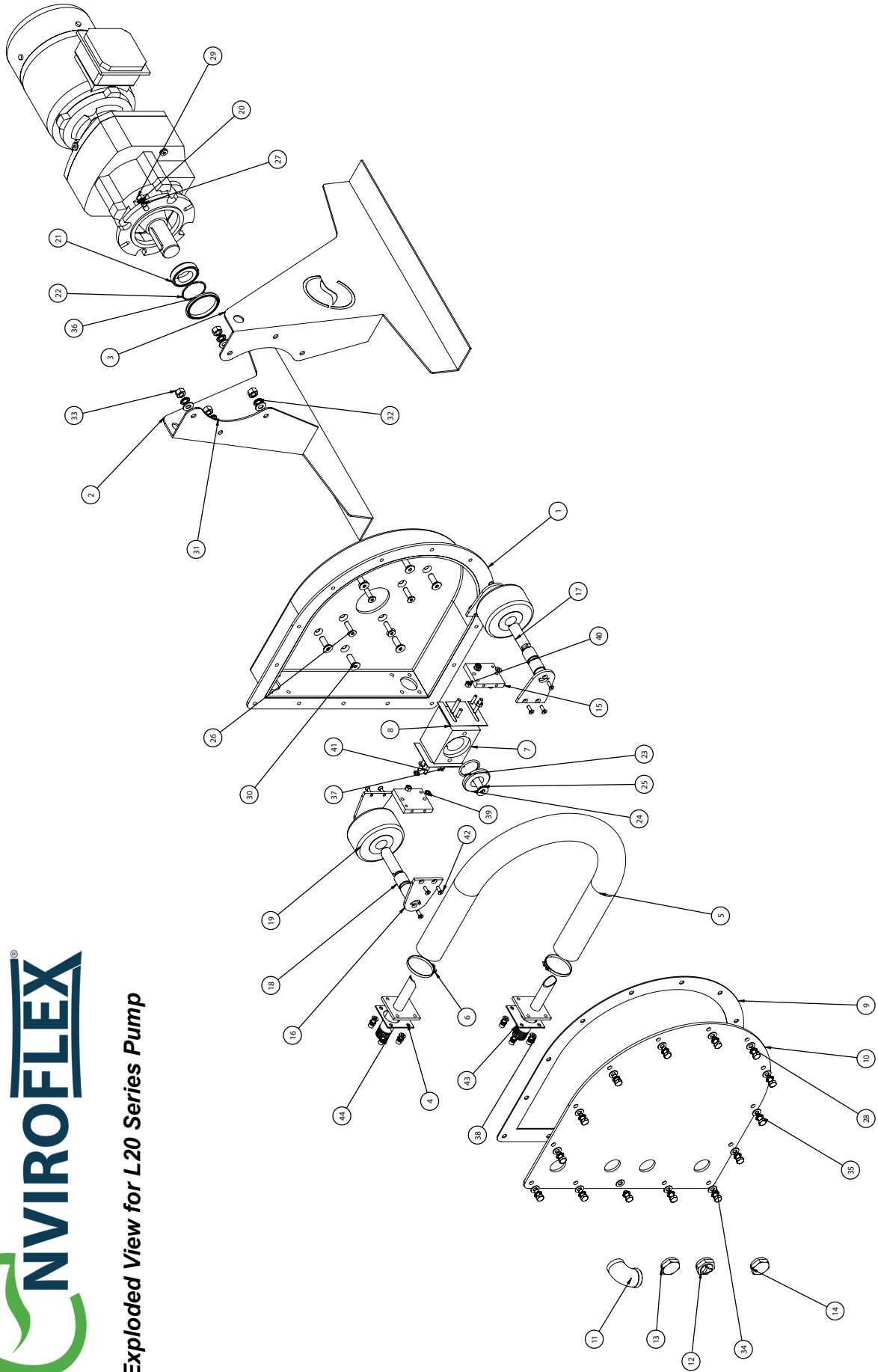

L20 Series Pump Parts List

Item No.	Part Number	Description	* Weight (gramme) Per Unit	Qty.
1	L-20-PH-1	Housing Body	10257.62	1
2	L-20-F-L-1	Pump Frame Left	3329.15	1
3	L-20-F-R-1	Pump Frame Right	3329.16	1
4	L-20-HC-CS-1	Hose Flange Seal	6.40	2
5**	L-20-NRH	Pump Hose - NATURAL RUBBER	1324.25	1
	L-20-NRH-FG	Pump Hose - NATURAL RUBBER (FOOD GRADE)	1324.25	1
	L-20-NIT-IND	Pump Hose - NITRILE (INDUSTRIAL)	1324.25	1
	L-20-NIT-FG	Pump Hose - NITRILE (FOOD GRADE)	1324.25	1
	L-20-EPDM	Pump Hose - EPDM	1324.25	1
	L-20-HYP	Pump Hose - HYPALON	1324.25	1
6**	LC-4016	Hose Clip	8.88	2
7	L-20-R-1	Rotor	802.91	1
8	L20/L25-SH-3 / L20/L25-SH-4	Shim 0.6mm / Shim 1.0mm	19.15	4/8
9	L-20-FC-DS-1	Front Cover Door Seal	126.70	1
10	L-20-FC-1	Front Cover	6753.39	1
11	LT-5100S	Breather Elbow	101.92	1
12	LT-5012	Sight Glass	32.68	1
13	LP-1001	Fill Plug	28.81	1
14	LP-1002	Drain Plug	28.81	1
15	L-20-ROL-M-1	Roller Mount	266.78	2
16	L-20-ROL-SP-1	Roller Side Plate	169.30	4
17	L-20-ROL-SH-2	Roller Shaft	144.44	2
18	L-20-ROL-B-1	Roller Bush	27.59	4
19	L-20-ROL-1	Roller	362.62	2
20	L-20-Gearbox	Gearbox		1
21	L-20-R-RS-3	Rotor Spacer	168.62	1
22	LS-6806	Rotor Spacer O Ring	0.55	1
23	LS-6100	Rotor Clamp Washer O Ring	1.39	1
24	L-20-R-RC-3	Roller Clamp Washer	105.89	1
25	LB-1266	Rotor Clamp Screw		1
26	LB-1215	Gearbox to Housing Fixing		4
27	LW-3001	Flat Washer		4
28	LW-3101	Spring Washer		18
29	LN-2000	Nut		4
30	LB-1227	Frame Mounting Screw		6
31	LW-3002	Flat Washer		6
32	LW-3102	Spring Washer		6
33	LN-2002	Nut		6
34	LW-3001	Flat Washer		14
35	LB-1012	Front Cover Fixing		14
36	LS-6001	Drive Protection Seal		1
37	LB-1278	Roller Mount Fixing		4
38	LW-3000	Flat Washer		12
39	LW-3100	Spring Washer		12
40	LN-4010	Nut		4
41	LD-7008	Roller Mount Dowel		4
42	LB-1257	Roller Shaft Fixing		12
43	LB-1103	Hose Connector Fixing		8
44	L-20-HC-1	Hose Connector	349.12	2

* 1 g = 0.0353 ounce / 0.0022 pound

** Recommended spares with 2.5 litres of Envirolube Lubricant.



Exploded View for L25 Series Pump

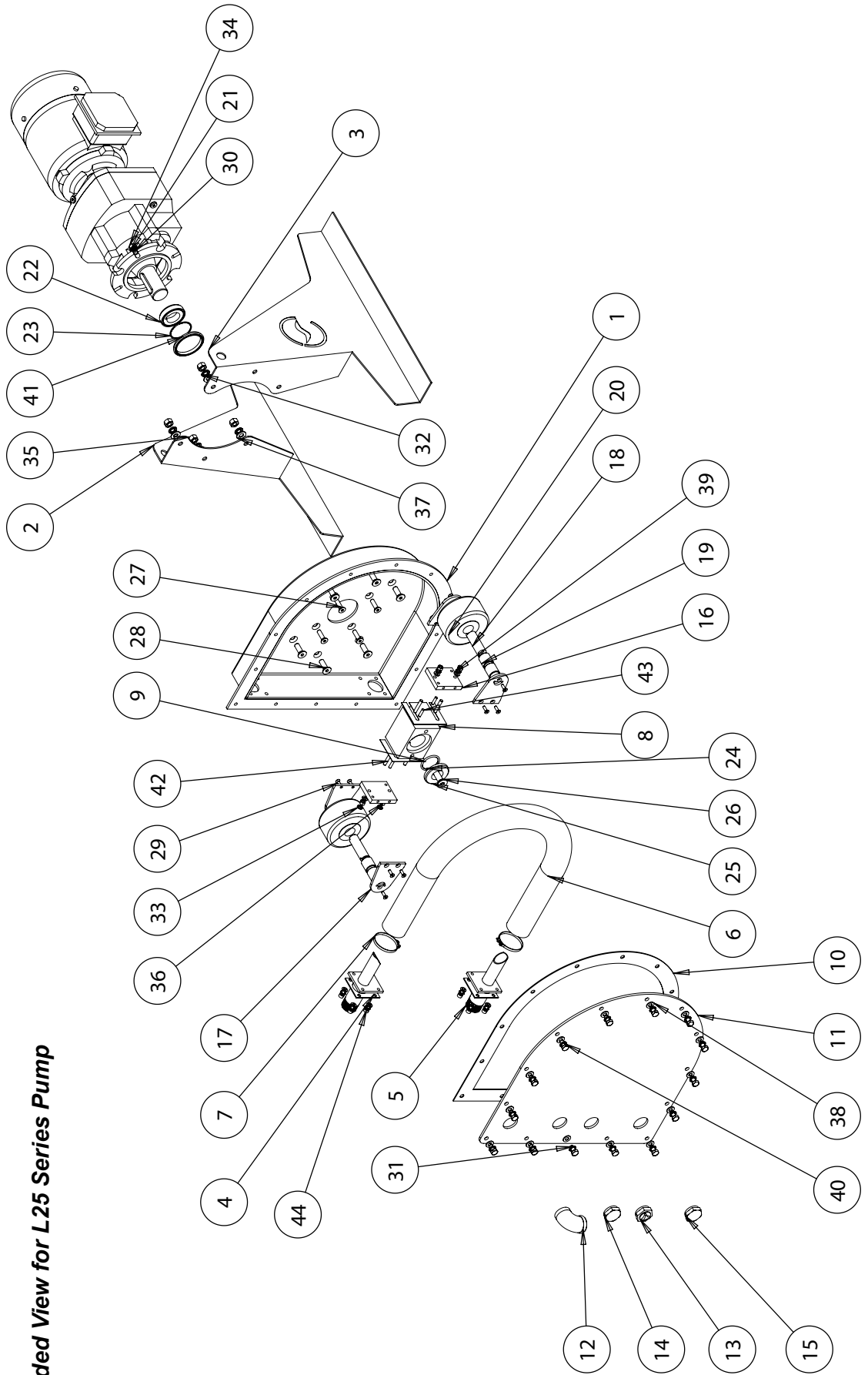

L25 Series Pump Parts List

Item No.	Part Number	Description	* Weight (gramme) Per Unit	Qty.
1	L-25-PH-1	Housing Body	10261.38	1
2	L-25-F-L-1	Pump Frame Left	3329.15	1
3	L-25-F-R-1	Pump Frame Left	3329.16	1
4	L-25-HC-CS-1	Hose Flange Seal	6.40	2
5	L-25-HC-1	Hose Connector	440.46	2
6**	L-25-NRH	Pump Hose - NATURAL RUBBER	1324.25	1
	L-25-NRH-FG	Pump Hose - NATURAL RUBBER (FOOD GRADE)	1324.25	1
	L-25-NIT-IND	Pump Hose - NITRILE (INDUSTRIAL)	1324.25	1
	L-25-NIT-FG	Pump Hose - NITRILE (FOOD GRADE)	1324.25	1
	L-25-EPDM	Pump Hose - EPDM	1324.25	1
	L-25-HYP	Pump Hose - HYPALON	1324.25	1
7**	LC-4016	Hose Clip	8.88	2
8	L-25-R-1	Rotor	802.91	1
9	L20/L25-SH-3 / L20/L25-SH-4	Shim 0.6mm / Shim 1.0mm	19.15	4/8
10	L-25-FC-DS-1	Front Cover Door Seal	126.95	1
11	L-25-FC-1	Front Cover	6753.39	1
12	LT-5100S	Breather Elbow	101.92	1
13	LT-5012	Sight Glass	32.68	1
14	LP-1001	Fill Plug	28.81	1
15	LP-1002	Drain Plug	28.81	1
16	L-25-ROL-M-1	Roller Mount	266.78	2
17	L-25-ROL-SP-1	Roller Side Plate	169.30	4
18	L-25-ROL-SH-2	Roller Shaft	144.44	2
19	L-25-ROL-B-1	Roller Bush	27.59	4
20	L-25-ROL-1	Roller	362.62	2
21	L-25-Gearbox	Gearbox		1
22	L-25-R-RS-3	Rotor Spacer	168.62	1
23	LS-6806	Rotor Spacer O Ring	0.55	1
24	LS-6100	Rotor Clamp Washer O Ring	1.39	1
25	L-25-R-RC-3	Roller Clamp Washer	105.89	1
26	LB-1266	Rotor Clamp Screw		1
27	LB-1215	Gearbox to Housing Fixing		4
28	LB1227	Frame Mounting Fixing		6
29	LB-1257	Roller Side Plate Fixing		12
30	LW-3001	Flat Washer		4
31	LW-3101	Spring Washer		18
32	LW-3102	Spring Washer		6
33	LW-3100	Spring Washer		12
34	LN-2000	Nut		4
35	LN-2002	Nut		6
36	LN-4010	Nut		4
37	LW-3002	Flat Washer		6
38	LW-3001	Flat Washer		14
39	LW-3000	Flat Washer		12
40	LB-1012	Front Cover Fixing		14
41	LS-6001	Drive Protection Seal		1
42	LB-1278	Roller Mount Fixing		4
43	LD-7008	Roller Mout Dowel		4
44	LB-1103	Hose Connector Fixing		8

* 1 g = 0.0353 ounce / 0.0022 pound

** Recommended spares with 2.5 litres of Envirolube Lubricant.



Exploded View for L32 Series Pump

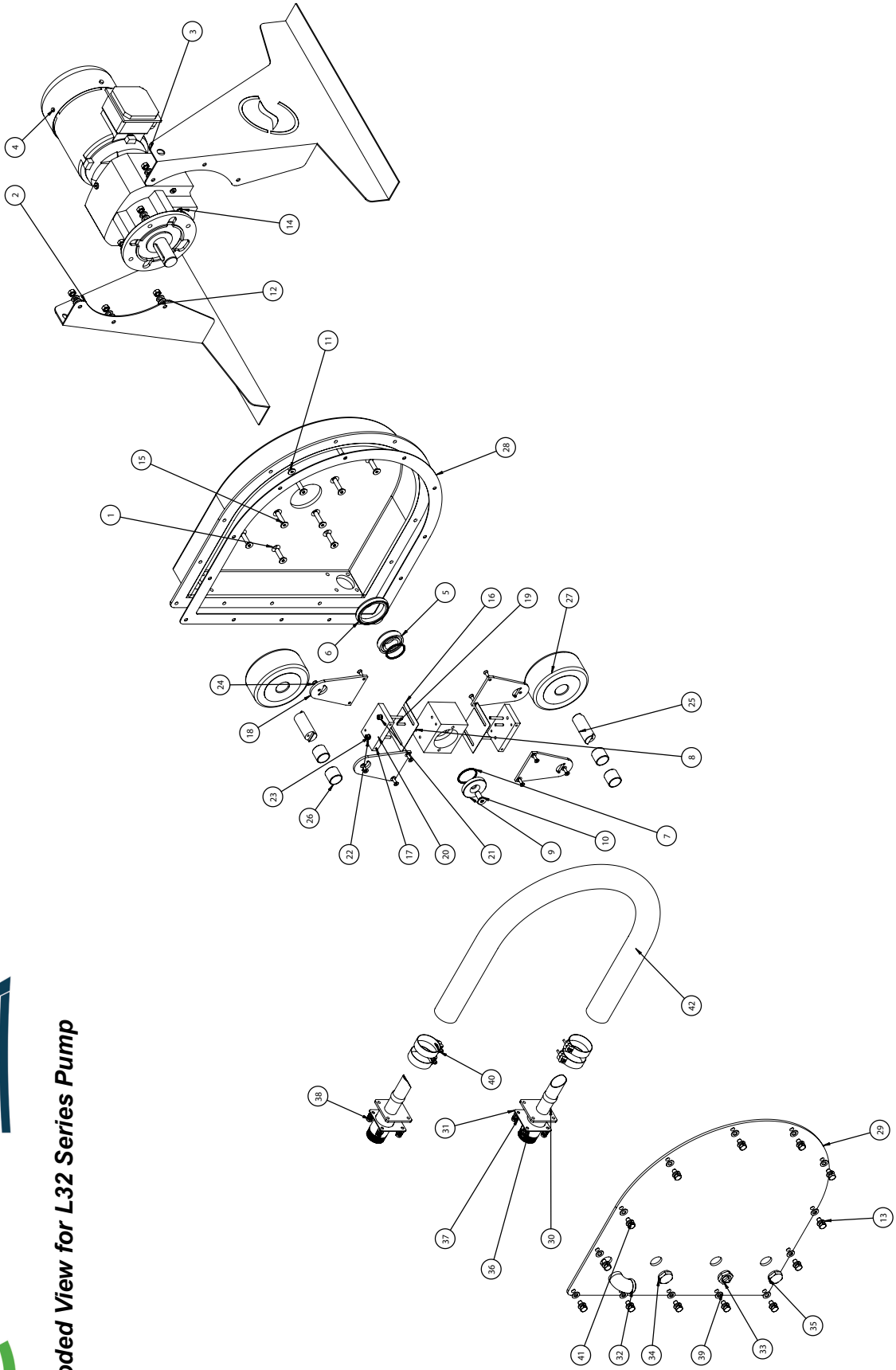

L32 Series Pump Parts List

Item No.	Part Number	Description	* Weight (gramme) Per Unit	Qty.
1	L-32-PH-1	Housing Body	43351.56	1
2	L-32-F-R-1	Pump Frame Right	5120.60	1
3	L-32-F-L-1	Pump Frame Left	5120.61	1
4	L-32-Motor and Gearbox	Motor and Gearbox	11678.00356	1
5	L-32-R-RS-1	Rotor Spacer	335.17	1
6	LS-6300	Drive Protection Seal	28.50	1
7	LS-6301	Rotor Clamp O Ring	1.37	2
8	L-32-R-1	Rotor	1389.90	1
9	L-32-R-RC-1	Rotor Clamp Washer	203.52	1
10	LB-1229	Rotor Clamp Bolt		1
11	LB-1235	Frame Mounting Screw		6
12	LW-3002	Flat Washer		10
13	LW-3102	Spring Washer		23
14	LN-2002	Nut		10
15	LB-1238	Gearbox Mounting Screw		4
16	L-32-SH-3 / L-32-SH-4	Shim 0.6mm / Shim 1.0mm	33.82	A/R
17	L-32-ROL-M-1	Roller Mount		2
18	L-32-ROL-SP-1	Roller Side Plate	492.51	4
19	LD-7000	Roller Mount Dowel		4
20	LB-1280	Roller Mount Fixing		4
21	LB-3000	Flat Washer		4
22	LB-3100	Spring Washer		4
23	LN-4010	Nut		4
24	ISO 10642 - M6 x 20 --- 20N			12
25	L-32-ROL-SH-1	Roller Shaft	396.39	2
26	L-32-ROL-B-1	Roller Bush	48.04	4
27	L-32-ROL-1	Roller	1011.40	2
28	L-32-FC-DS-1	Front Cover Door Seal	185.28	1
29	L-32-FC-1	Front Cover	15612.36	1
30	L-32-HC-1	Hose Connector	1047.97	2
31	L-32-HC-CS-1	Hose Flange Seal	9.79	2
32	LT-5100S	Breather Elbow	101.921	1
33	LT-5012	Sight Glass	32.68	1
34	LP-1001	Fill Plug	28.81	1
35	LP-1002	Drain Plug	28.81	1
36	LW-3001	Flat Washer		8
37	LW-3101	Spring Washer		8
38	LB-1231	Hose Connector Screw		8
39	LW-3002	Flat Washer		13
40**	LC-4017	Hose Clamp L32	51.31	4
41	LB-1037	Front Cover Screw		13
42**	L-32-NRH	Pump Hose - NATURAL RUBBER	3096.60	1
	L-32-NRH-FG	Pump Hose - NATURAL RUBBER (FOOD GRADE)	3096.60	1
	L-32-NIT-IND	Pump Hose - NITRILE (INDUSTRIAL)	3096.60	1
	L-32-NIT-FG	Pump Hose - NITRILE (FOOD GRADE)	3096.60	1
	L-32-EPDM	Pump Hose - EPDM	3096.60	1
	L-32-HYP	Pump Hose - HYPALON	3096.60	1

* 1 g = 0.0353 ounce / 0.0022 pound

** Recommended spares with 5.0 litres of Envirolube Lubricant.



Exploded View for L40 Series Pump

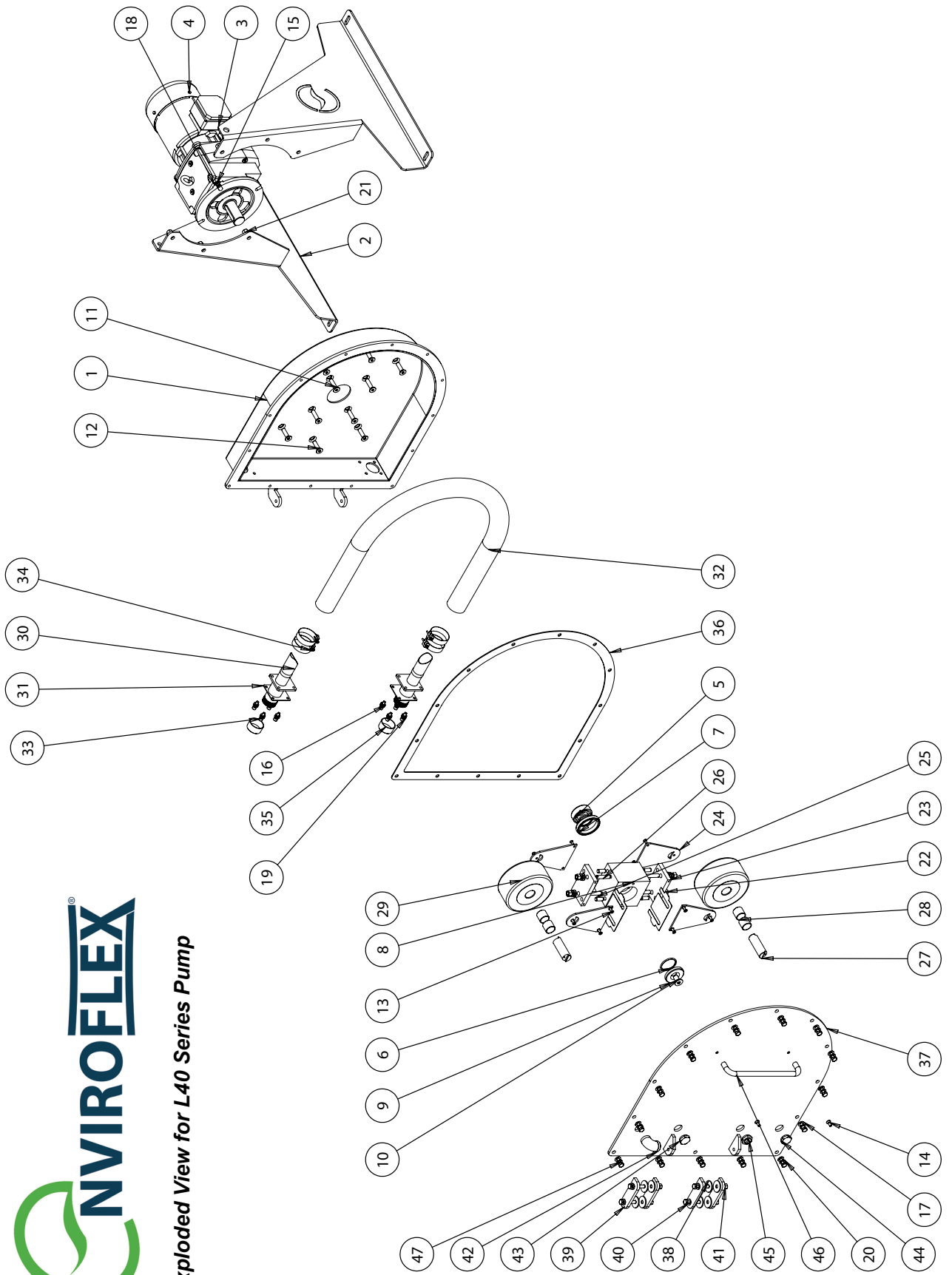

L40 Series Pump Parts List

Item No.	Part Number	Description	* Weight (gramme) Per Unit	Qty.
1	L-40-PH-1	Housing Body	40104.81	1
2	L-40-F-L-1	Pump Frame Left	13140.98	1
3	L-40-F-R-1	Pump Frame Right	13140.99	1
4	L40 Gearbox			1
5	L-40-R-RS-1	Rotor Spacer	431.91	1
6	LS-6814	Rotor Spacer O Ring	2.61	2
7	LS-6400	Drive Protection Seal		1
8	L-40-R-2	Rotor	3312.65	1
9	L-40-R-RC-1	Rotor Clamp Washer	223.08	1
10	LB-3239	Rotor Clamp Screw		1
11	LB-3230	Gearbox Mounting Screw		4
12	LB-3228	Frame Mounting Screw		6
13	LB-3232	Roller Shaft Screw		12
14	LB-3213	Front Cover Handle Fixing		2
15	LW-5003	Flat Washer M12		14
16	LW-5001	Flat Washer M8		8
17	LW-5002	Flat Washer M10		22
18	LW-5103	Spring Washer M12		14
19	LW-5108	Spring Washer M8		8
20	LW-5102	Spring Washer M10		14
21	LN-4003	Nut M12		14
22	L-40-SH-3 / L-40-SH-4	Shim 0.6mm / Shim 1.0mm	46.49	4/8
23	L-40-ROL-M-2	Roller Mount		2
24	L-40-ROL-SP-1	Roller Side Plate	529.524	
25	LD-7007	Roller Mount Dowel		4
26	LB-3274	Hinge Screw		4
27	L-40-ROL-SH-1	Roller Shaft		2
28	L-40-ROL-B-1	Roller Bush	48.04	4
29	L-40-ROL-1	Roller	1810.39	2
30	L-40-HC-1	Hose Connector	880.00	2
31	L-40-HC-CS-1	Hose Connector Seal	9.87	2
32**	L-40-NRH	Pump Hose - NATURAL RUBBER	3925.32	1
	L-40-NRH-FG	Pump Hose - NATURAL RUBBER (FOOD GRADE)	3925.32	1
	L-40-NIT-IND	Pump Hose - NITRILE (INDUSTRIAL)	3925.32	1
	L-40-NIT-FG	Pump Hose - NITRILE (FOOD GRADE)	3925.32	1
	L-40-EPDM	Pump Hose - EPDM	3925.32	1
	L-40-HYP	Pump Hose - HYPALON	3925.32	1
33	LB-3294	Hose Connector Screw		8
34**	LC-4018	Hose Clip	54.28	4
35	L-40-CON-CAP	Hose Connector Cap	10.95	2
36	L-40-FC-DS-1	Front Door Seal	325.07	1
37	L-40-FC-1	Front Cover	28906.19	1
38	L-40-62	Friction Hinge Washer	3.95	8
39	L-40-59	Hinge Link Plate		4
40	LB-3274	Hinge Screw		4
41	LN-4012	Nyloc Nut M10		4
42	LT-5100S	Breather Elbow	101.92	1
43	LP-1001	Fill Plug	28.81	1
44	LP-1002	Drain Plug	28.81	1
45	LT-5012	Sight Glass	32.68	1
46	LH-4000	Handle	227.52	1
47	LB-3026	Front Cover Screw		14

* 1 g = 0.0353 ounce / 0.0022 pound

** Recommended spares with 7.5 litres of Envirolube Lubricant.



Exploded View for L50 Series Pump

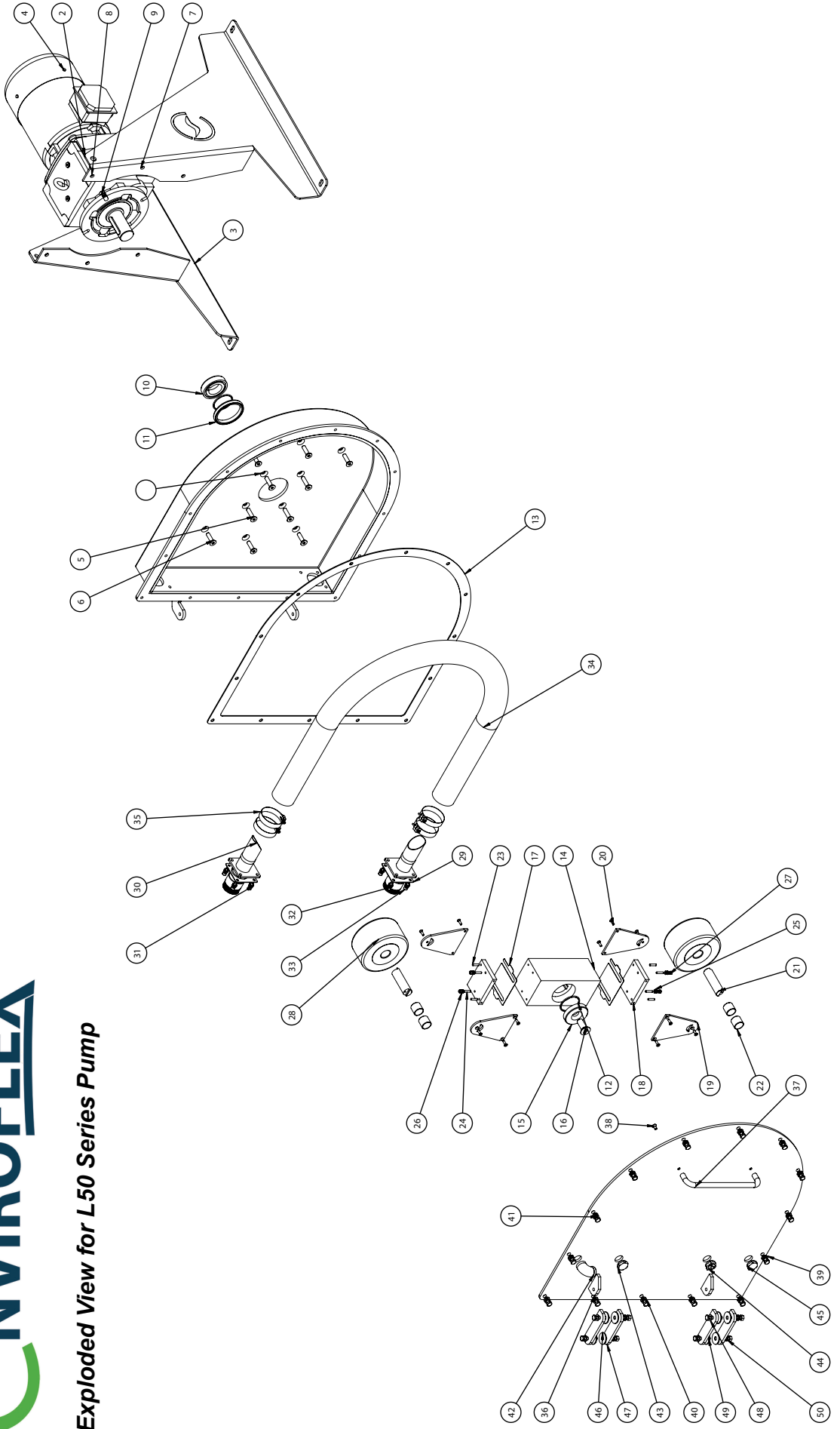

L50 Series Pump Parts List

Item No.	Part Number	Description	* Weight (gramme) Per Unit	Qty.
1	L-50-PH-1	Housing Body	88040.96	1
2	L-50-F-L-1	Pump Frame Left	16263.51	1
3	L-50-F-R-1	Pump Frame Right	16263.51	1
4	D-L-50-Gear Box and Motor	Gearbox and Motor		1
5	LB-1230	Gearbox Mounting Screw		4
6	LB-1228	Frame Mounting Screw		6
7	LW-3003	Flat Washer		10
8	LW-3103	Spring Washer		10
9	LN-2003	Nut		10
10	L-50-R-RS-1	Rotor Spacer	736.67	1
11	LS-6500	Drive Protection Seal		1
12	LS-6501	Rotor Clamp O Ring	2.52	2
13	L-50-FC-DS-1	Front Door Seal	406.99	1
14	L-50-R-1	Rotor	7789.00	1
15	L-50-R-RC-1	Rotor Clamp Washer	655.71	1
16	LB-1240	Rotor Clamp Screw		1
17	L-50-SH-1 / L-50-SH-2	Shim 0.6mm / Shim 1.0mm	53.09	4/8
18	L-50-ROL-M-1	Roller Mount		2
19	L-50-ROL-SP-1	Roller Side Plate	636.01	4
20	LB-1232	Roller Side Plate Screw		12
21	L-50-ROL-SH-1	Roller Shaft		2
22	L-50-ROL-B-1	Roller Bush	48.04	4
23	LD-7000	Roller Mount Dowel		4
24	LB-1281	Roller Mount Fixing		4
25	LB-3000	Flat Washer		4
26	LB-3100	Spring Washer		4
27	LN-4010	Nut		4
28	L-50-ROL-1	Roller	2111.27	2
29	L-50-HC-CS-1	Hose Connector Seal	12.73	2
30	L-50-HC-1	Hose Connector	1079.04	2
31	LW-3001	Flat Washer		8
32	LW-3101	Spring Washer		8
33	LB-1231	Hose Connector Screw		8
34**	L-50-NRH	Pump Hose - NATURAL RUBBER	6722.09	1
	L-50-NRH-FG	Pump Hose - NATURAL RUBBER (FOOD GRADE)	6722.09	1
	L-50-NIT-IND	Pump Hose - NITRILE (INDUSTRIAL)	6722.09	1
	L-50-NIT-FG	Pump Hose - NITRILE (FOOD GRADE)	6722.09	1
	L-50-EPDM	Pump Hose - EPDM	6722.09	1
	L-50-HYP	Pump Hose - HYPALON	6722.09	1
35**	LC-4019	Hose Clip	61.21	4
36	L-50-FC-1	Front Cover	39753.58	1
37	LH-4000	Handle	227.52	1
38	LB-1269	Front Cover Handle Fixing		2
39	LW-3002	Flat Washer		14
40	LW-3102	Spring Washer		18
41	LB-1026	Front Cover Screw		14
42	LT-5100S	Breather Elbow	101.92	1
43	LP-1001	Fill Plug	28.81	1
44	LT-5012	Sight Glass	32.68	1
45	LP-1002	Drain Plug	28.81	1
46	L-50-67	Friction Hinge Washer	3.95	8
47	L-50-66	Hinge Link Plate		4
48	LW-3002	Flat Washer		8
49	LB-1274	Hinge Screw		4
50	LN-2002	Nut		4

* 1 g = 0.0353 ounce / 0.0022 pound

** Recommended spares with 10 litres of Envirolube Lubricant.



Exploded View for L65 Series Pump

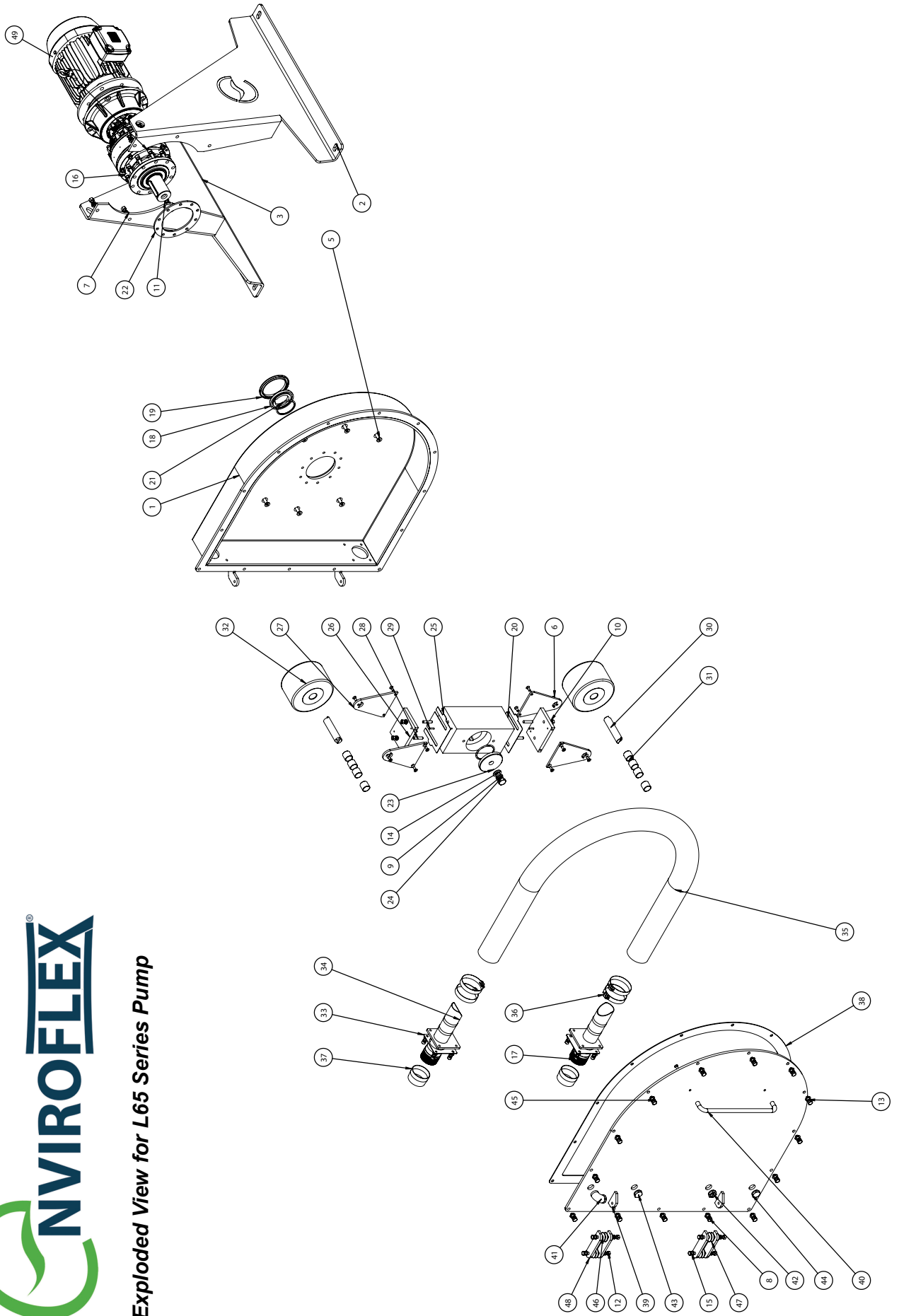

L65 Series Pump Parts List

Item No.	Part Number	Description	* Weight (gramme) Per Unit	Qty.
1	L-65-PH-1	Housing Body	123018.97	1
2	L-65-F-L-1	Pump Frame Left	35654.28	1
3	L-65-F-R-1	Pump Frame Right	35654.23	1
4	L-65-Gearbox	Gearbox	48719.85	1
5	LB-3230	Frame Mounting Screw		6
6	LB-3213	Roller Side Plate and Roller Shaft Screw		14
7	LW-5003	Flat Washer		6
8	LWS-5103	Spring Washer		20
9	LW-5104	Spring Washer		1
10	LW-5102	Spring Washer		16
11	LN-4003	Nut		6
12	LN-5102	Nut		8
13	LW-5003	Flat Washer		24
14	LW-5004	Flat Washer		1
15	LW-5002	Flat Washer		20
16	LB-3270	Gearbox Mounting Screw		10
17	LB-3275	Hose Connector Screw		8
18	L-65-R-RS-1	Rotor Spacer	538.21	1
19	LS-6800	Drive Protection Seal	29.95	1
20	L-65-R-1	Rotor	15093.56	1
21	LS-6801	Rotor Spacer O Ring	6.12	2
22	L-65-81	Gearbox Spacer	931.56	1
23	L-65-R-RC-1	Rotor Clamp Washer	894.79	1
24	LB-3271	Rotor Clamp Bolt		1
25	L-65-SH-1 / L-65-SH-2	Shim 0.6mm / Shim 1.0mm	88.54	A/R
26	L-65-ROL-M-1	Roller Mount	2223.85	2
27	L-65-ROL-SP-1	Roller Side Plate	1220.17	4
28	LB-3279	Roller Mount Fixing		4
29	LD-7000	Roller Mount Dowel		4
30	L-65-ROL-SH-1	Roller Shaft	710.05	2
31	L-65-ROL-B-1	Roller Bush	48.85	8
32	L-65-ROL-1	Roller	3664.83	2
33	L-65-HC-CS-1	Hose Connector Seal	24.44	2
34	L-65-HC-1	Hose Connector	2369.20	2
35**	L-65-NRH	Pump Hose - NATURAL RUBBER	11681.65	1
	L-65-NRH-FG	Pump Hose - NATURAL RUBBER (FOOD GRADE)	11681.65	1
	L-65-NIT-IND	Pump Hose - NITRILE (INDUSTRIAL)	11681.65	1
	L-65-NIT-FG	Pump Hose - NITRILE (FOOD GRADE)	11681.65	1
	L-65-EPDM	Pump Hose - EPDM	11681.65	1
	L-65-HYP	Pump Hose - HYPALON	11681.65	1
36**	LC-4020	Hose Clip	70.69	4
37	L-65-CON-CAP	Hose Connector Cap	32.86	2
38	L-65-FC-DS-1	Front Door Seal	609.75	1
39	L-65-FC-1	Front Cover	68786.85	1
40	LH-4001	Handle	288.81	1
41	LT-5100S	Breather Elbow	101.92	1
42	LT-5012	Sight Glass	32.68	1
43	LP-1001	Fill Plug	28.81	1
44	LP-1002	Drain Plug	28.81	1
45	LB-3242	Front Cover Screw		14
46	LB-3274	Hinge Screw		4
47	L-65-56	Friction Hinge Washer	3.95	8
48	L-65-53	Hinge Link Plate	411.16	4
49	Motor	Motor		1

* 1 g = 0.0353 ounce / 0.0022 pound

** Recommended spares with 20 litres of Envirolube Lubricant.



Exploded View for L80 Series Pump

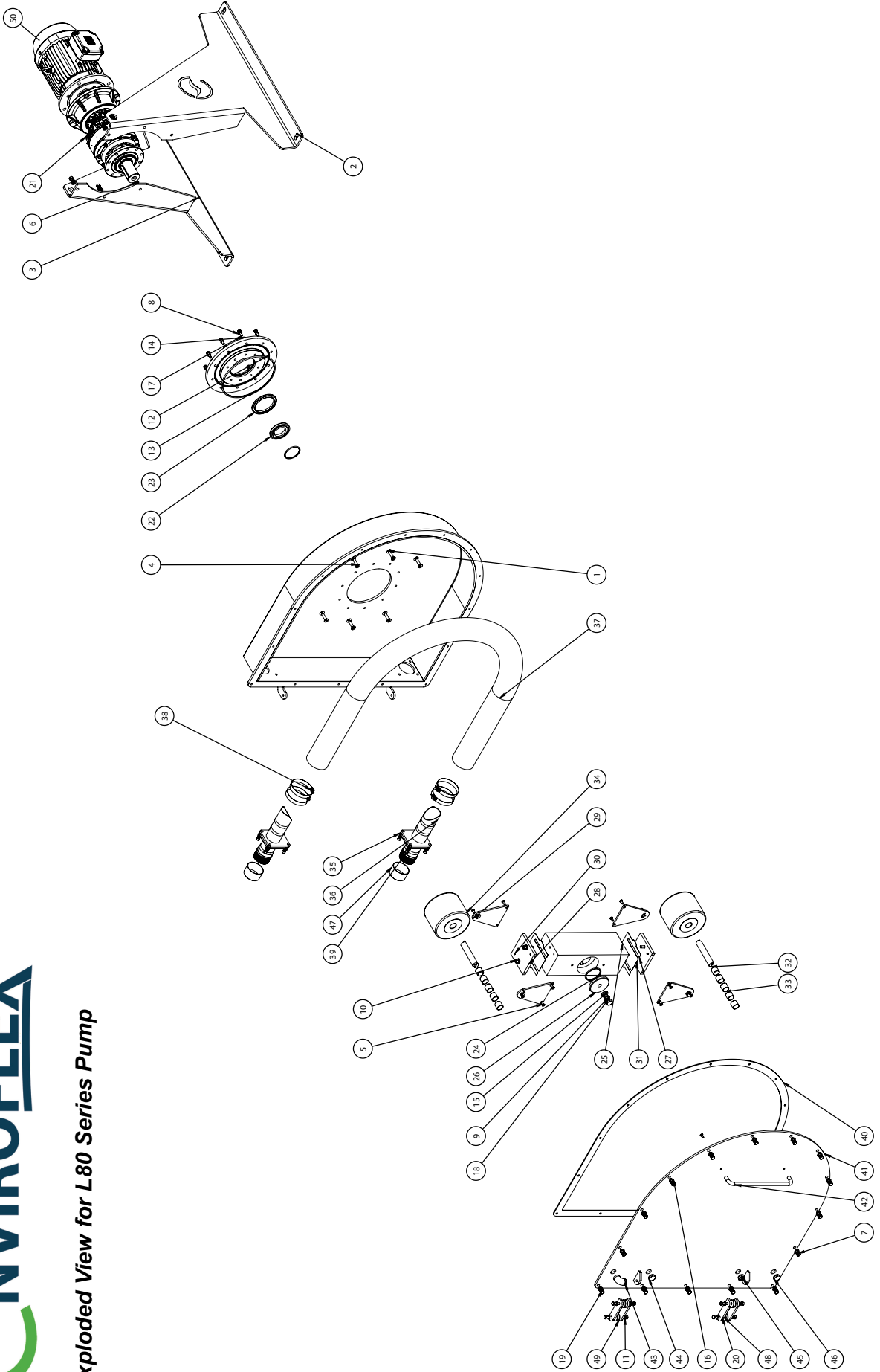

L80 Series Pump Parts List

Item No.	Part Number	Description	* Weight (gramme) Per Unit	Qty.
1	L-80-PH-1	Housing Body	187658.33	1
2	L-80-F-L-1	Pump Frame Left	41936.39	1
3	L-80-F-R-1	Pump Frame Right	41936.37	1
4	LB-3230	Frame Mounting Screw		6
5	LB-3213	Roller Shaft and Roller Side Plate Screw		14
6	LW-5003	Flat Washer		6
7	LW-5103	Spring Washer		25
8	LW-5102	Spring Washer		22
9	LW-5104	Spring Washer		1
10	LN-4003	Nut		10
11	LN-4002	Nut		4
12	L-80-GB-MF-1	Gearbox Mounting Flange	15616.15	1
13	LS-6814	Rotor Spacer O Ring	34.11	1
14	LW-5002	Flat Washer		26
15	LW-5004	Flat Washer		1
16	LB-5003	Flat Washer		19
17	LB-3236	Gearbox Mounting Screw		10
18	LB-3243	Rotor Clamp Bolt		1
19	LB-3242	Front Cover Screw		15
20	LB-3274	Hinge Screw		4
21	L-80-Gearbox	Gearbox	48719.85	1
22	L-80-R-RS-1	Rotor Spacer	579.00	1
23	LS-6800	Drive Protection Seal	23.31	1
24	LS-6801	Rotor Clamp O Ring	6.12	2
25	L-80-R-1	Rotor	27573.15	1
26	L-80-R-RC-1	Rotor Clamp Washer	877.10	1
27	L-80-SH-1 / L-80-SH-2	Shim 0.6mm / Shim 1.0mm	106.08	A/R
28	L-80-ROL-M-1	Roller Mount	2768.59	2
29	L-80-ROL-SP-1	Roller Side Plate	1183.66	4
30	LD-7002	Roller Mount Dowel		4
31	LB-3282	Roller Mount Fixing		4
32	L-80-ROL-SH-1	Roller Shaft	865.89	2
33	L-80-ROL-B-1	Roller Bush	48.04	10
34	L-80-ROL-1	Roller	4519.05	2
35	L-80-HC-CS-1	Hose Connector Seal	24.97	2
36	L-80-HC-1	Hose Connector	2611.40	2
37**	L-80-NRH	Pump Hose - NATURAL RUBBER	11681.65	1
	L-80-NRH-FG	Pump Hose - NATURAL RUBBER (FOOD GRADE)	11681.65	1
	L-80-NIT-IND	Pump Hose - NITRILE (INDUSTRIAL)	11681.65	1
	L-80-NIT-FG	Pump Hose - NITRILE (FOOD GRADE)	11681.65	1
	L-80-EPDM	Pump Hose - EPDM	11681.65	1
	L-80-HYP	Pump Hose - HYPALON	11681.65	1
38**	LC-4021	Hose Clip	80.59	4
39	LB-3244	Hose Connector Screw		8
40	L-80-FC-DS-1	Front Door Seal	913.61	1
41	L-80-FC-1	Front Cover	91983.49	1
42	LH-4001	Handle	288.81	1
43	LT-5100S	Breather Elbow	101.92	1
44	LP-1001	Fill Plug	28.81	1
45	LT-5102	Sight Glass	32.68	1
46	LP-1002	Drain Plug	28.81	1
47	L-80-CON-CAP	Hose Connector Cap	36.55	2
48	L-80-56	Friction Hinge Washer	3.95	8
49	L-80-53	Hinge Link Plate	411.16	4
50	Motor	Motor		1

* 1 g = 0.0353 ounce / 0.00220 pound

** Recommended spares with 25 litres of Envirolube Lubricant.

4 User Guide

4.1 Troubleshooting

If the pump does not appear to be functioning correctly, consult the following guide to see if you can identify and remedy the problem yourself. If the problem still persists, please contact Environmental Pumping Solutions Limited or your authorised local dealer for more detailed information.

Problem	Probable Cause(s)	Suggested Remedy
The pump does not start when turned on.	Defective motor	Check motor is running Check fuses. Check motor protection switch Make sure that all phases have required voltage
	Frequency inverter (when used) incorrectly set-up	Connect motor DOL Check inverter settings
	Shaft key broken or missing	Make sure that a key is fitted and that all surfaces of friction are clean and undamaged. The hub screws are correctly tightened
	Pump rotating in reverse	Check direction of the motor is correct
	The pump is taking in air	Identify the source of air intake and exchange seals or gaskets
	Rollers are not adjusted correctly	Adjust the roller occlusion
Pump runs but there is no flow of media	Hose blocked	Reverse the pumps rotation and remove any obstacles. If this is not possible with your system, the pump needs to be disassembled and obstacles removed.
	Pipeline on suction side of the pump is clogged	Clean pipeline, valves, filters etc.
	Pump has pumped against excessive pressure and hose has detached from hose connector	Remove reason for overpressure, fit overpressure protection, check pump for damage and reattach hose and refill lube
Flow is less than calculated	Pump is running too slow	It maybe possible to fit a speed inverter or make a gear ratio change (not always possible). Call Environmental Pumping Solutions Ltd. to discuss
	The pump is taking in air	Locate the source of air intake and exchange seals or gaskets
Flow is less than calculated	Restriction in the suction pip	Identify and remove the restriction
	Viscosity is too high for the size of pump	Turn down the pump speed and/or utilise a larger pump

Problem	Probable Cause(s)	Suggested Remedy
Flow is less than calculated	Rollers are not adjusted correctly	Adjust the roller occlusion
	Backpressure is too high	Change the pipeline on the pressure side of the pump
	Suction pipe is too long for the diameter creating too high suction pulsation losses	Consult Environmental Pumping Solutions Ltd.
Noise	Pump cavitating	Lower the speed or utilise a bigger pump or change the pipelines
	Air or gas in the pipelines	Seal off possible air intakes
	Pressure too high	Clear pipelines and check pipe sizes Lower the pumping speed
	Rollers are not adjusted correctly	Adjust the roller occlusion
	Gearwheels or bearings worn out	Workshop overhaul of pump needed
	Hose damaged	Exchange the hose
	Suction and discharge lines not correctly fastened	Fasten correctly
Vibration of the pump and pipework	High pump speed with long suction and discharge lines or high product specific gravity or a combination of these factors	Reduce pump speed. Reduce the line lengths on both suction and discharge where possible. Consult Environmental Pumping Solutions Ltd.
	Too small diameter of suction and/or discharge pipework	Increase the pipework size
	Pressure too high	Check discharge pressure is as per pump data sheet. Check pump speed is as per pump data sheet. Check pipelines are clear Check pump hose is not damaged (New installation) Check pipes sized correctly
Pump draws too much current	Sedimentation of solid substance when not using the pump	Empty the pump after use, flush the pump with clean water after use
	Fluid or particle buildup in or by the motor	Clean the motor
	High pump speed	Reduce pump speed or install larger pump
Short Hose Life	Hose Deteriorating chemically	Reassess the choice of material for the hose
	High pulsations	Consult Environmental Pumping Solutions Ltd. for detailed advice
	Incorrect hose lubricant used	Use only Envirolube lubricant
Pump parts wearing quickly	Hose wearing mechanically on the outside	Check compression roller occlusion

Problem	Probable Cause(s)	Suggested Remedy
Pump parts wearing quickly	Hose wearing mechanically on the inside	Check compression roller occlusion
	Roller bearings (bushings) wear down quickly	Check compression roller occlusion
	Abrasive product mixed in the hose lubricant	Wash out pump body and change lubricant. Ensure pump body is fully cleaned when replacing a failed hose
High pump temperature	Incorrect hose lubricant used	Use only Envirolube lubricant
	Product temperature too high	Consult Environmental Pumping Solutions Ltd.
	Pump running too fast	Reduce pump speed
	Possible restriction in the suction pipe	Dismantle the suction piping, identify the restriction and remove
Lubricant leakage	Leaking seal or gasket	Identify the leaking seal or gasket. Tighten retaining bolts. Replace seal or gasket if needed

For trouble free pump operation, please refer also to the [Routine Maintenance](#) instructions as detailed earlier in this manual.

4.2 Specifications

4.2.1 Pump operating conditions

Description	L20	L25	L32	L40	L50	L65	L80
Max continuous flow (m ³ /hr)	1.2*	2.21*	4.00*	6.5*	10.4*	19.2*	25.9*
Capacity per revolution (l/rev)	0.23	0.41	0.95	1.82	3.46	7.10	12.33

Maximum working pressure	10 Barg*
Ambient working temperature	-15°C to +45°C
Product working temperature	-10°C to +80°C
Sound level at 1m	< 70 dB(A) whilst pumping water at maximum continuous flow

* Your pump may not have been configured to run at these stated maximums. Please check your Technical Data Sheet.

4.2.2 Materials of Construction

Description	Standard	Optional	
Pump Body	Carbon Steel	304 st. stl.	316 st. stl.
Front Cover	Carbon Steel	304 st. stl.	316 st. stl.
Rotor	Carbon Steel	304 st. stl.	316 st. stl.
Compression Rollers	POM		
Hose connectors	304 st. stl.	316 st. stl.	
Support Frame	304 st. stl.		316 st. stl.
Gasket Frame	Nitrile		
Fasteners	MS BZP	304 st. stl.	316 st. stl.

4.2.3 Hose Lubricant Quantities

Pump Model	L20	L25	L32	L40	L50	L65	L80
Volume of hose lubricant (litres)	2.5	2.5	5.0	7.5	10	20	25



Contact Environmental Pumping Solutions Limited or your authorised local dealer should you require a Material Safety Data Sheet (MSDS) for Envirolube hose lubricant.

4.2.4 Weights and Dimensions

The details below are approximate only. Please refer to your Technical Data Sheet or Environmental Pumping Solutions for specific details of the supplied equipment.

Pump Model	L20	L25	L32	L40	L50	L65	L80
Net weight (kgs)	65	65	155	250	300	375	540
Overall size (mm)	536H 513W 503L	536H 513W 503L	723H 691W 670L	857H 790W 750L	986H 852W 790L	1134H 1067W 889L	1319H 1242W 994L

4.3 Recommendations for Hose Storage

We recommend that pump hoses are stored in accordance with BS3574. Peristaltic hoses can be considered as Group A products as detailed in this specification, i.e. products with moderate susceptibility to deterioration.

The relevant points from this specification are:

Temperature:	To be below 25°C and articles stored away from direct sources of heat such as boilers, radiators and direct sunlight. For articles stored below 15°C their temperature should be raised to approx. 30°C throughout their mass prior to use.
Humidity:	Humidity shall be such that condensation shall not occur. The criterion for this is that either the storage temperature should be above the dew point or humidity levels should be low enough to ensure the dew point is below the storage temperature.
Light:	Protect from strong light sources, in particular direct sunlight or intense artificial light having a high ultraviolet content.
Ozone:	Storage areas shall not contain equipment which generates ozone - e.g. mercury vapour lamps, high voltage electrical equipment, combustion gases, organic vapours.
Deformation:	Store free from superimposed tensions or compression. For a hose this means that the supports must be wide enough and spaced in a way as to spread the load over a wide area. We would recommend a minimum width of 100mm for any support spaced no more than 500mm apart. It is preferable that hoses are supported over their entire length. Do not store hoses coiled.
Contact with Liquids:	Do not allow contact with liquids (e.g. petrol, greases, acids, disinfectants, cleaning fluids).
Contact between Hoses:	Avoid direct contact between hoses of different types, particularly between hoses of different colours.
Rotation of Stock:	Hoses must be issued in strict rotation by manufacturing date or production code.

Hoses will be delivered wrapped individually in opaque polythene, we would recommend that the packing is kept on the hoses prior to use to reduce the effects of light and to minimise contact with other materials. Individual hoses are marked with a production code identifying the manufacturing period.

EC Declaration of Conformity

In accordance with EN ISO 17050-1:2004

We Environmental Pumping Solutions Limited
of Elcot Park, Elcot Lane, Marlborough, Wiltshire, SN8 2BG United Kingdom
in accordance with the following Directive(s):

2004/108/EC The Electromagnetic Compatibility Directive
 2006/42/EC The Machinery Directive

hereby declare that:

Equipment Peristaltic Pump
 Models L20, L25, L32, L40, L50, L65, L80

is in conformity with the applicable requirements of the following documents

Ref. No.	Title	Edition/date
BS EN ISO 12100-1	Safety of machinery. Basic concepts, general principles for design. Basic terminology, methodology	2003
BS EN ISO 12100-2	Safety of machinery. Basic concepts, general principles for design. Technical principles	2003
BS EN 809	Pumps and pump units for liquids. Common safety requirements	1998
BS EN 60204-1	Safety of machinery. Electrical equipment of machines. General requirements	2006 +A1:2009
BS EN 61000-6-1	Electromagnetic compatibility (EMC). Generic standards. Immunity for residential, commercial and light-industrial environments	2007
BS EN 61000-6-3	Electromagnetic compatibility (EMC). Generic standards. Emission standard for residential, commercial and light-industrial environments	2007

I hereby declare that the equipment named above has been designed to comply with the relevant sections of the above referenced specifications and is in accordance with the requirements of the Directive(s)

Signed by:

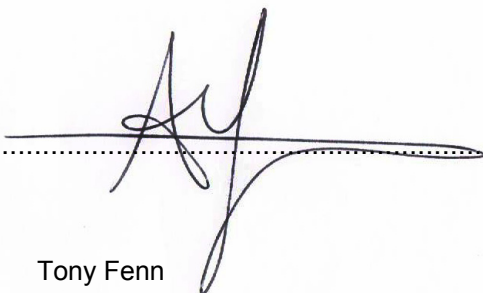

Name: Tony Fenn
 Position: Sales Director
 Done at Marlborough, Wiltshire, UK
 On November 2012



The technical documentation for the machinery is available from the manufacturer at the above address.

Product Use Declaration Form

In compliance with the Health & Safety Regulations and the Control of Substances Hazardous to Health Regulations you, the user are required to declare the substances which have been in contact with the product(s) you are returning to Environmental Pumping Solutions Limited or any of its subsidiaries or distributors. Failure to do so will cause delays in servicing the item or in issuing a response. Therefore, please complete this form to ensure that we have the information before receipt of the items(s) being returned. **A FURTHER COPY MUST BE ATTACHED TO THE OUTSIDE OF THE PACKAGING CONTAINING THE ITEM(S)** before returning. You, the user, are responsible for cleaning and decontaminating the item(s) before returning them.

Please complete a separate Declaration Form for each item returned.

Company:
 Address:
 Postcode:
 Telephone: Fax Number:
 e-mail:

Product: Cleaning fluids to be used if residue product is found during servicing:
 Serial Number: 1.
 Has the Product been used? 2.

YES		NO	
-----	--	----	--

 3.
 4.

If yes, please complete all the following sections

If no, please complete declaration only

Details of Substances Pumped

Chemical names:

1.
2.
3.
4.

Precautions to be taken when handling the above:

1.
2.
3.
4.

Action to be taken in the event of human contact:

1.
2.
3.
4.

I hereby confirm that the only substance(s) that the item specified has handled or come into contact with are those named, that the information given is correct, and the carrier has been informed if the consignment is of a hazardous nature.

Signed:

Name:

Position:

Date:

Any other additional information you may regard as useful:

.....

